

BMD Series

Permanent Magnet AC
Synchronous Motors

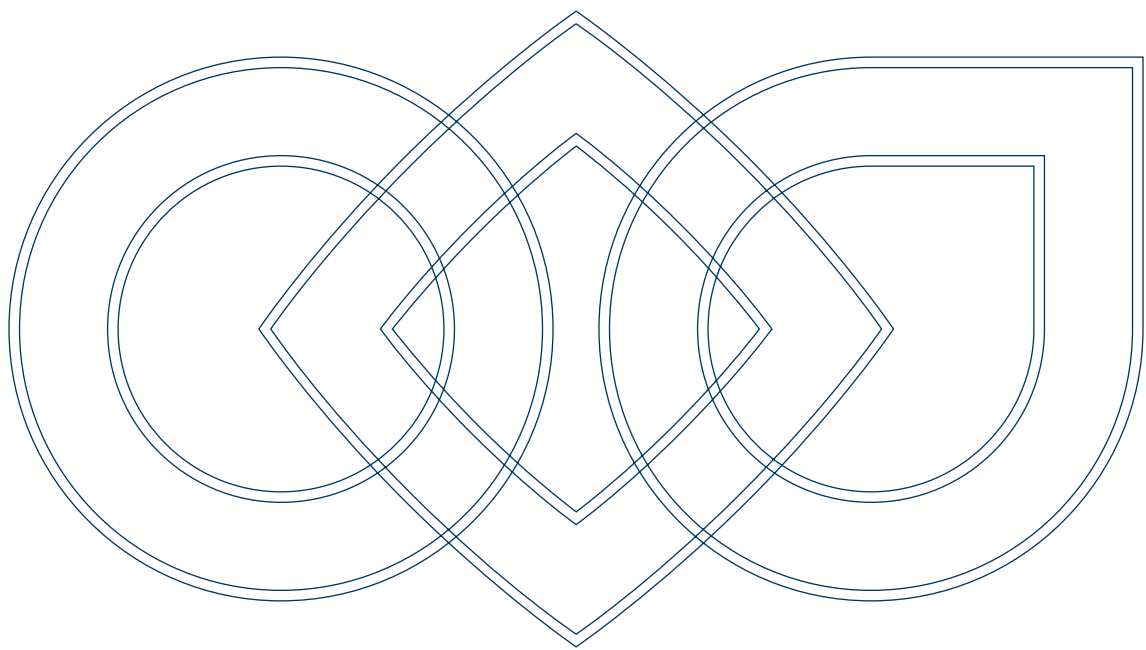

PRODUCTS &
SOLUTIONS



Index

5 Focus on synchronous servomotors

Sevomotor references

- 6 Standard and Directives
- 7 Symbols and Unit of Measures
- 8 Terms and Definition
- 10 Rating Plates
- 11 Selecting the Servomotor
- 14 Degree of Protection

Series overview

- 15 Bonfiglioli Permanent Magnet Synchronous Servomotor Range
- 16 Product Designation

Mechanical data

- 18 Coupling Dimensions
- 19 Mechanical Tolerances
- 20 Shaft Loads

Ratings and drawings

- 22 BMD 65
- 24 BMD 82
- 26 BMD 102
- 28 BMD 118
- 30 BMD 145
- 32 BMD 145 with Force Ventilation Option
- 34 BMD 170
- 36 BMD 145 with Force Ventilation Option
- 38 Torque-speed characteristics

Options

- 46 Feedback Devices
- 50 Thermal Protection
- 50 Electromechanical Holding Brake
- 51 Additional Inertia feature
- 51 Forced Ventilation
- 53 Connections and Cables
- 62 Servo gearheads

68 Bonfiglioli Worldwide Presence

Focus on our synchronous servomotors

These permanent magnet AC synchronous servomotors are ideal for any type of automatic machinery in particular applications with high dynamic requirements. They are particularly suited to typical applications in plastic and metal machining, packaging, food and beverage processing, winding and textile industries.

The dimensions of the motor are drastically reduced, with considerable advantages in terms of torque density, overall dimensions and dynamic performance.

Thanks to the high quality of the neodymium iron boron rare-earth magnets, performance are maximized in terms of very high accelerations and withstand high overloads without risk of demagnetization of the magnets.

The motors are available in six frames covering a stall torque range between 0.85 ÷ 45 Nm with natural cooling and up to 60 Nm with forced ventilation.

These brushless sinusoidal motors are designed as standard for a three phase power supply, 230Vac and 400Vac.

BMD motor series are manufactured using class F insulation materials. The standard cooling method is free ventilation IC410. As option, the forced ventilation IC416 is available only for the size BMD 145 and BMD 170.

Since each servomotor has a protective temperature sensor (PTC, KTY or PT100) embedded in the motor windings, operating temperature is constantly acquired and monitored by the drive to prevent all risks of damage to the motor irrespective of operating conditions.

An optional electromechanical holding brake is available for all models. Brake operation is controlled entirely by the frequency inverter.

BMD motors are optionally available with an external additional flywheel mass to face the machine inertia.

BMD series are available with degree of protection IP65 (standard) and IP67 (optional).

The following feedback devices are available:

- Resolver with excitation frequency 8 and 10 kHz
- Single turn absolute SinCos interface
- Single turn and Multi-turn: Hiperface and EnDAT protocols supported
- No feedback versions (specific control algorithms with sensorless servo drive are required).

BMD Series servomotors are controlled in speed and/or torque by a suitable electronic servo drive. The servo drive therefore constitutes a fundamental part of the actuator and requires perfect synchronization with it in order to achieve optimum performance.

The combination of BMD servomotors with frequency inverters from Bonfiglioli inverters ensures the perfect control of the motor in order to optimise the performance according to the machine requirements.

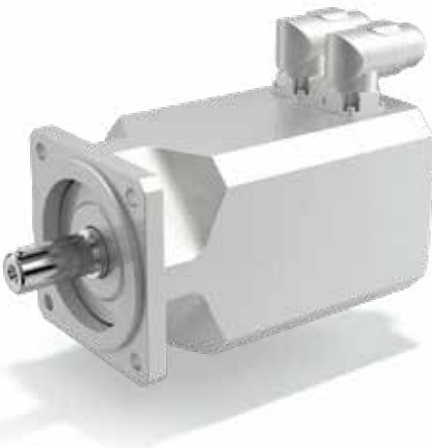

BMD Brushless motor photos used inside this catalogue do not represent the real product colour. The actual colour is black (RAL 9005). Silver dressing has to be intended for marketing and promotional purposes only.

Standards and directives

BMD motors are manufactured in accordance with applicable standards and Directive listed in the following.

STANDARD

IEC 60034-1, EN 60034-1

Rotating electrical machines
Part 1: Rating and performance

IEC 60034-2-3

Rotating electrical machines
Part 2-3: Specific test methods for determining losses and efficiency of converter-fed AC motor

IEC 60034-5, EN 60034-5

Rotating electrical machines
Part 5: Degrees of protection provided by the integral design of rotating electrical machines (IP code) - Classification

IEC 60034-6, EN 60034-6

Rotating electrical machines
Part 6: Methods of cooling (IC Code)

IEC 60034-8, EN 60034-8

Rotating electrical machines
Part 8: Terminal markings and direction of rotation

IEC 60034-14, IEC 60034-14

Rotating electrical machines
Part 14: Mechanical vibration - Measurement, evaluation and limits of vibration severity

IEC TS 60034-25

Rotating electrical machines
Part 25: Guidance for the design and performance of a.c. motors specifically designed for converter supply

IEC 60072-1

Dimensions and output series for rotating electrical machines - Part 1

DIRECTIVES

Low Voltage Directive: 2014/35/EU

The BMD servomotors series comply with UL/CSA standards for the North American market (UL file number E358266).

UL 1004-1

Rotating Electrical Machines
General Requirements

UL 1004-6

Servo and Stepper Motors

CSA C22.2 No. 100

Motors and Generators

Symbols and units of measure

| SYMBOL | U.M. | DESCRIPTION |
|----------------|--|---------------------------------------|
| $2p$ | [-] | Number of poles |
| dT | [K] | Winding temperature rise |
| f_H | [-] | Altitude adjustment factor |
| f_n | [Hz] | Rated frequency |
| f_T | [-] | Temperature adjustment factor |
| I_0 | [A] | Stall RMS current |
| I_b | [A] | Brake DC current |
| I_{max} | [A] | Max RMS current |
| I_n | [A] | Rated RMS current |
| J_b | [Kgm ² · 10 ⁻⁴] | Brake moment of inertia |
| J_M | [Kgm ² · 10 ⁻⁴] | Motor moment of inertia |
| K_e | [mV min ⁻¹] | Back EMF constant phase-phase |
| K_T | [Nm/A] | Torque constant |
| L_{pp} | [mH] | Stator phase-phase inductance |
| M_0 | [Nm] | Stall torque |
| M_b | [Nm] | Brake torque |
| m_b | [kg] | Brake mass |
| M_{EQU} | [Nm] | Equivalent torque |
| M_{max} | [Nm] | Max torque |
| m_M | [kg] | Motor mass without brake/ flywheel |
| M_n | [Nm] | Rated torque |
| n_n | [min ⁻¹] | Rated speed |
| P_b | [W] | Brake electrical power at 20°C |
| P_n | [kW] | Rated power |
| R_{pp} | [Ω] | Stator phase-phase resistance at 20°C |
| t_1 | [ms] | Brake engaging time |
| t_2 | [ms] | Brake release time |
| V_b | [V] | Brake DC voltage |
| V_n | [V] | Rated voltage |
| ΔJ | [Kgm ² · 10 ⁻⁴] | Inertia increase with brake/flywheel |
| Δm_M | [kg] | Mass increase with brake/flywheel |
| τ_{el} | [ms] | Electric time constant |
| τ_{therm} | [min] | Thermal time constant |

Unless otherwise specified, all dimensions are expressed in millimeters.

Terms and definitions

Back EMF constant [K_e]: is the relationship between the phase-to-phase RMS motor back EMF terminal voltage (V_{AC}) and the corresponding shaft rotational speed. It is typically computed as the RMS value of line voltage at speed of 1 min⁻¹ with a winding temperature of 20°C.

Duty type S1: Operation at constant load maintained for sufficient time to allow the machine to reach thermal equilibrium

Duty type S3: sequence of identical duty cycles, each including a time of operation at constant load and a time de-energized and at rest. If not specified the cycle time is fixed equal to 10 minutes.

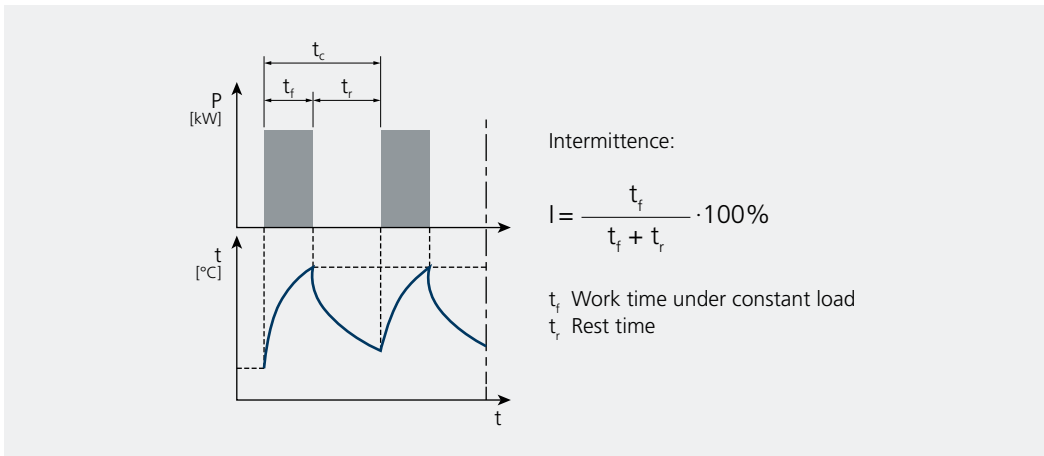

Electric time constant [τ_{el}]: is the time taken for the current to reach 63.2% of its steady state value when a step input voltage is applied while the rotor is stationary. Calculated by dividing the winding phase-to-phase inductance (L_{pp}) by the winding phase-to-phase resistance (R_{pp}) at 20°C.

$$\tau_{el} = L_{pp} / R_{pp}$$

Max current [I_{max}]: is the current used to produce the max torque (M_{max}). It is the current limit of the machine, and if exceeded, even for a short period, it may happen an irreversible damage of the machine.

Max torque [M_{max}]: is the absolute maximum torque that can be produced by a servomotor for a short time.

Rated current [I_n]: is the RMS current to produce the rated torque (M_n).

Rated frequency [f_n]: is the frequency of the fundamental component of the output voltage corresponding at the rated speed (n_n) according to the following equation where p is the pole pairs.

$$f_n = p \cdot n_n / 60$$

Terms and definitions

Rated power [P_n]: is the mechanical power available at shaft at rated speed n_n .

$$P_n = 2\pi \cdot M_n \cdot n_n / 60$$

Rated speed [n_n]: is the speed at which the motor has been designed to operate with a reasonable level of control, in terms of overload and overspeed.

Rated torque [M_n]: is the thermally permissible continuous torque for S1 duty at the rated motor speed (n_n). It is normally less than the standstill torque (M_0) due to rotational losses (iron losses, friction losses...).

Standstill current [I_0]: is the RMS current to produce the standstill torque (M_0).

Standstill torque [M_0]: is the thermal limit torque for S1 duty produced when the motor runs at zero speed.

Thermal equilibrium: is the state reached when the temperature rise of the several parts of the machine do not vary by more than a gradient of 2 K per hour.

Thermal time constant [τ_{therm}]: is the time for the temperature to reach 63.2% of this final value between the motor housing and the ambient after a step-wise current change.

Torque constant [K_t]: is the phase RMS current to torque transfer ratio at standstill condition. It is quoted at rated motor winding temperature in steady state condition (thermal equilibrium – S1 duty cycle).

Winding temperature rise [dT]: is the temperature rise, in specified service conditions, of the motor windings above the maximum ambient reference temperature.

Rating plates

In accordance with IEC 60034-1, the motor rating plate summarizes the motor rating including the approximate total weight. Example of rating plate and fields description are reported hereafter.

Fields:

- 1) Product designation
- 2) Product code
- 3) Stall torque
- 4) Nominal torque
- 5) Nominal voltage
- 6) Stall current
- 7) Nominal current
- 8) Nominal speed
- 9) Insulation class
- 10) Degree of protection
- 11) Total weight
- 12) Motor mounting
- 13) Number of poles
- 14) Nominal brake voltage⁽¹⁾
- 15) Nominal brake torque⁽¹⁾
- 16) Nominal brake current⁽¹⁾
- 17) UL certification logo⁽²⁾
- 18) Serial number
- 19) Serial number as barcode

⁽¹⁾ Only for brake motors (F24 option)

⁽²⁾ Only for motors with CUS option

Example of BMD rating plate:

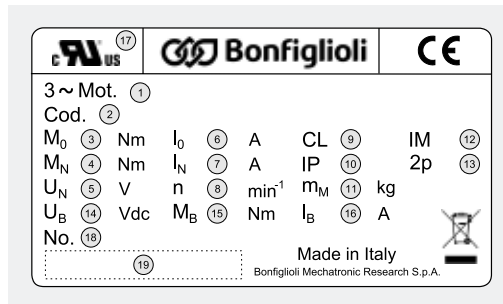

The fan unit data are summarized in a dedicated rating plate. Example of rating plate and fields description are reported hereafter.

Fields:

- 1) Product code
- 2) Nominal voltage
- 3) Nominal power
- 4) Degree of protection
- 5) Product code as barcode

Example of fan unit rating plate:

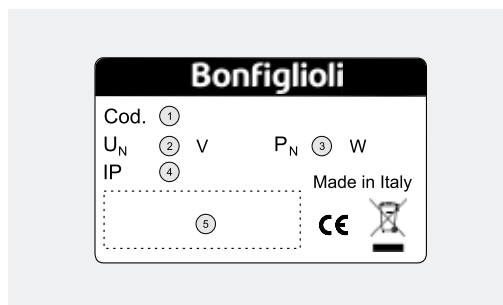

Selecting the servomotor

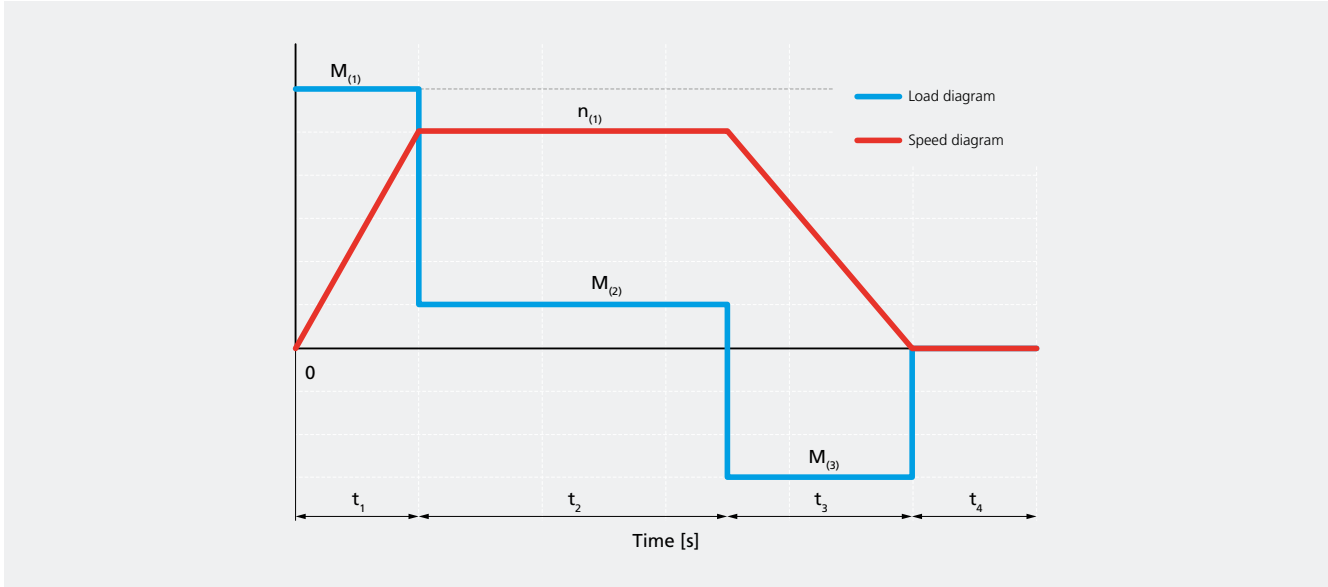

| | | | | |
|------------|------------------------------|-----------|------|--|
| (a) | Equivalent torque | M_{EQU} | [Nm] | $M_{EQU} = \sqrt{\frac{M_{(1)}^2 \cdot t_1 + M_{(2)}^2 \cdot t_2 + \dots + M_{(n)}^2 \cdot t_n}{t_1 + t_2 + \dots + t_n}}$ |
| (b) | Temperature adjusting factor | f_T | - | |
| (c) | Altitude adjustment factor | f_H | - | |

Selecting the servomotor

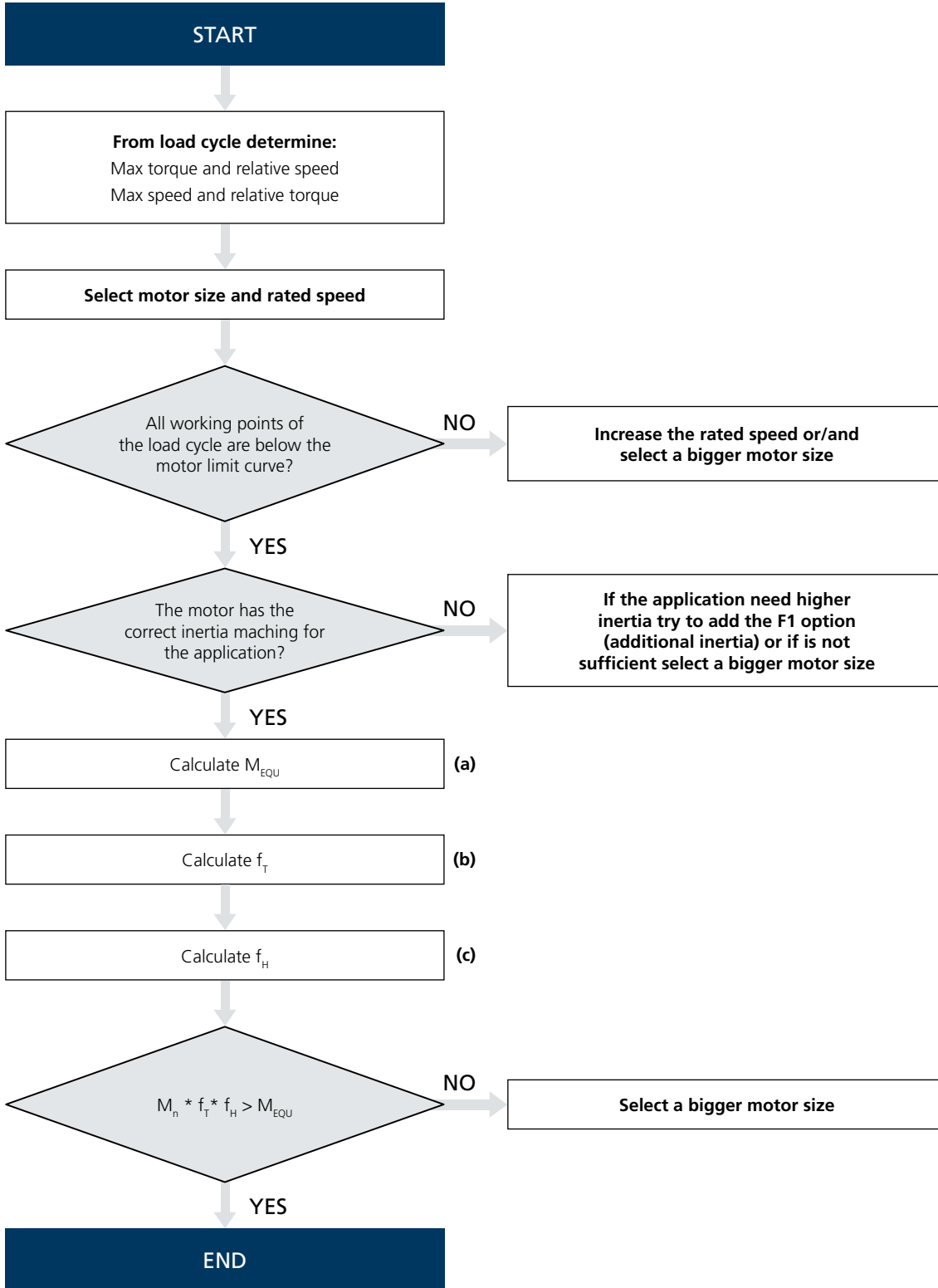

Feedback selection

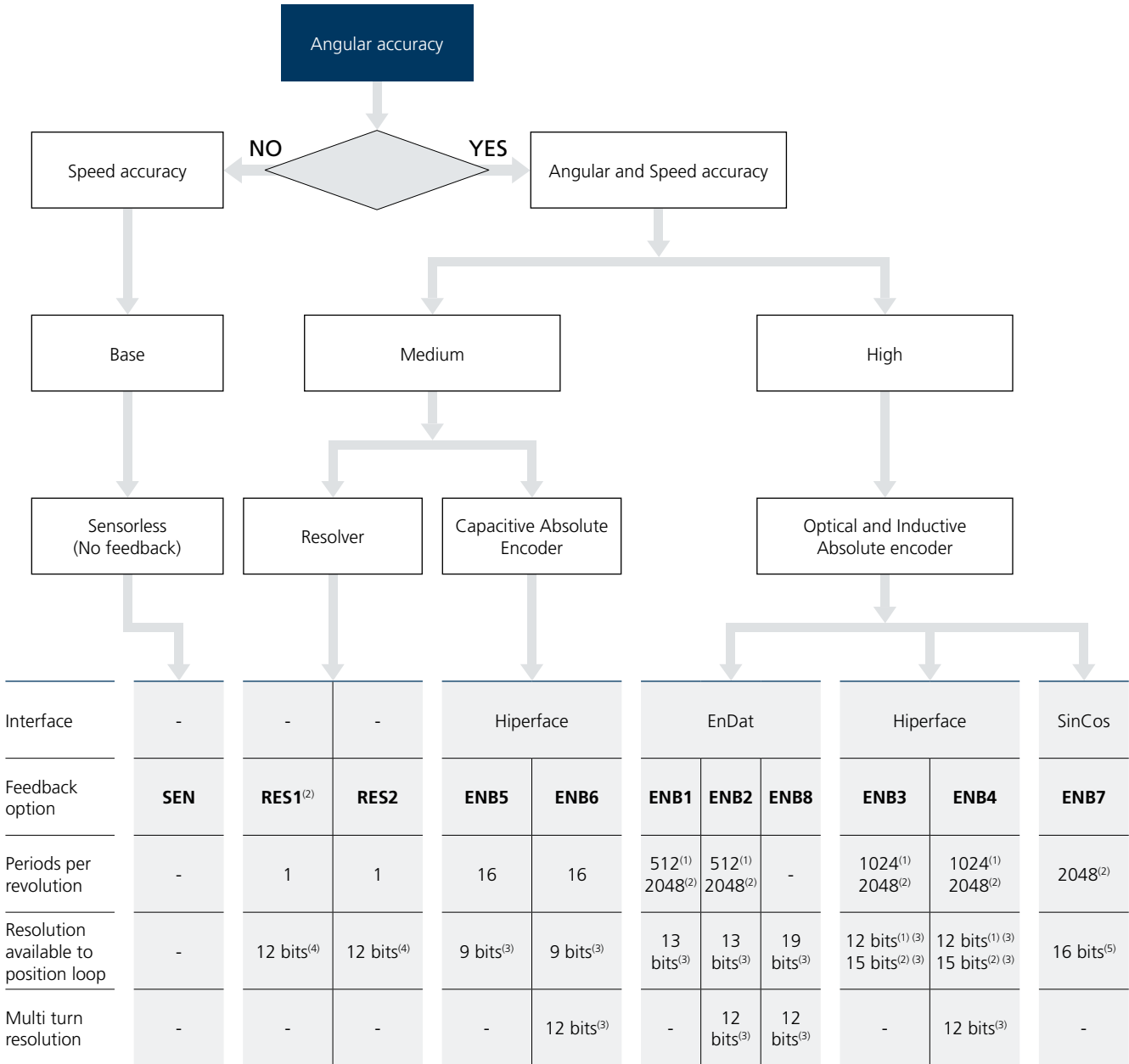

1) Only for size BMD 65

2) For the sizes from BMD 82 to BMD 170

3) The information is supplied by the feedback device manufacturer. The values may change when mounted into motor and connected to a drive.

4) The output from the resolver is analog output. The resolution of the system is also determined by the analog to digital converter used. This resolution is obtained when used with the EM-RES-01/02 acquisition module.













5) The output is analog and the resolution of the system is also determined by the analog to digital converter used. This resolution is obtained when used with the EM-ABS-01 acquisition module.

Please check the compatibility with our Motion Control with our Technical team or by consulting the Motion Control catalogue.

Degree of protection

BMD motors are manufactured in protection class IP65 or IP67 by selecting the basic variant "degree of protection" in the designation.

In accordance with IEC 60034-5:

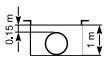
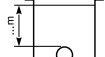
| IP | | 6 | 5 | | |
|----------|---|---|----------|---|---|
| 0 | | Not protected | 0 | | Not protected |
| 1 |  | Protected against extraneous solid bodies having $\varnothing \geq 50$ mm | 1 |  | Protected against vertical water drips |
| 2 |  | Protected against extraneous solid bodies having $\varnothing \geq 12.5$ mm | 2 |  | Protected against vertical water drips inclined up to 15° |
| 3 |  | Protected against extraneous solid bodies having $\varnothing \geq 2.5$ mm | 3 |  | Protected against rain |
| 4 |  | Protected against extraneous solid bodies having $\varnothing \geq 1.0$ mm | 4 |  | Protected against water splashes |
| 5 |  | Protected against dust | 5 |  | Protected against jets of water |
| 6 |  | No dust ingress | 6 |  | Protected against powerful jets of water |
| | | | 7 |  | Protected against the effects of temporary immersion |
| | | | 8 |  | Protected against the effects of continuous immersion |

Bonfiglioli permanent magnet synchronous servomotors range

The Bonfiglioli permanent magnet synchronous motors are available in six sizes with stall torque comprises between 0.85 ÷ 60 Nm.

Product Line Up

- Competitive technology
- Low inertia
- Highest dynamics
- High torque density
- Precision
- Compact design

BMD series

Stall Torque distribution

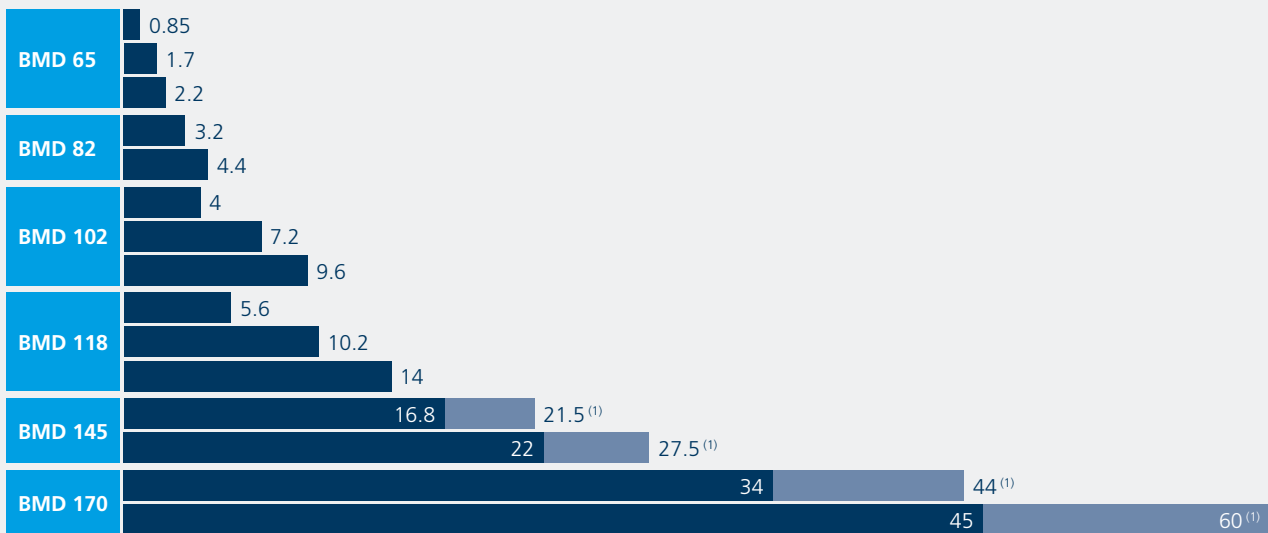

A brief overview of the available combinations of the basic variants such as motor size, motor stall torque, nominal voltage and nominal speed is reported in the following table.

| | | BMD 65 | | | BMD 82 | | BMD 102 | | | BMD 118 | | BMD 145 | | | BMD 170 | | | | | |
|----------|----------|--------|-----|-----|--------|-----|---------|-----|-----|---------|------|---------|------|---------------------|---------|---------------------|----|-------------------|----|-------------------|
| | | 0.85 | 1.7 | 2.2 | 3.2 | 4.4 | 4 | 7.2 | 9.6 | 5.6 | 10.2 | 14 | 16.8 | 21.5 ⁽¹⁾ | 22 | 27.5 ⁽¹⁾ | 34 | 44 ⁽¹⁾ | 45 | 60 ⁽¹⁾ |
| 400 V | 1600 rpm | | X | X | X | X | X | X | X | X | X | X | X | X | X | X | X | X | X | X |
| | 3000 rpm | X | X | X | X | X | X | X | X | X | X | X | X | X | X | X | X | X | X | X |
| | 4500 rpm | X | X | X | X | X | X | X | X | X | X | X | X | X | X | X | | | | |
| | 5500 rpm | X | X | X | X | X | X | X | X | X | X | X | X | X | X | | | | | |
| 230 V | 6000 rpm | X | X | X | X | X | X | X | X | X | X | X | | | | | | | | |
| | 1600 rpm | X | X | X | X | X | X | X | X | X | X | X | X | X | X | X | X | X | | |
| | 3000 rpm | X | X | X | X | X | X | X | X | X | X | X | X | X | X | | X | X | | |
| | 4500 rpm | X | X | X | X | X | X | X | X | X | X | | | | | | | | | |
| | 5500 rpm | X | X | X | X | X | X | X | X | X | X | | | | | | | | | |
| 6000 rpm | X | X | X | X | X | X | X | X | X | | | | | | | | | | | |

(1) Motor with forced ventilation option

Product designation of Bonfiglioli servomotors

BASIC VARIANTS

| | | | | | | | | |
|------------|------------|-----------|-------------|------------|------------|-----------|--|---|
| BMD | 145 | 22 | 3000 | 400 | 165 | 24 | K | 65 |
| | | | | | | | | Degree of protection 65 IP65 67 IP67 |
| | | | | | | | Shaft keyway K with key NK without key | |
| | | | | | | | Shaft diameter 9 size 65 11 size 65, 82 14 size 82 19 size 82, 102, 118, 145 24 size 102, 118, 145, 170 28 size 118, 145, 170 32 size 170 | |
| | | | | | | | Flange⁽¹⁾ 63 size 65 75 size 65 100 size 82, 102 115 size 82, 102 130 size 118 130S size 118 165 size 118, 145, 170 | |
| | | | | | | | | Motor AC voltage⁽²⁾ 230 400 |
| | | | | | | | | Motor rated speed⁽²⁾ 1600 (min ⁻¹) 3000 (min ⁻¹) 4500 (min ⁻¹) 5500 (min ⁻¹) 6000 (min ⁻¹) |
| | | | | | | | | Motor stall torque 0.85 (Nm) size 65 1.7 (Nm) size 65 2.2 (Nm) size 65 3.2 (Nm) size 82 4.4 (Nm) size 82 4 (Nm) size 102 7.2 (Nm) size 102 9.6 (Nm) size 102 5.6 (Nm) size 118 10.2 (Nm) size 118 14 (Nm) size 118 16.8 (Nm) size 145 22 (Nm) size 145 34 (Nm) size 170 45 (Nm) size 170 |
| | | | | | | | | Motor size 65, 82, 102, 118, 145, 170 |
| | | | | | | | | Series BMD |

OPTIONAL VARIANTS

| PTC | RES1 | P1 | S1 | F24 | CUS | V1R |
|--|--|----|---|--|---|---|
| | | | | | | |
| | | | | | | <p>Forced ventilation ⁽⁴⁾</p> <p>(blank) no forced ventilation (default)</p> <p>V1R 24V DC IP 54 angled rotatable receptacle</p> <p>V1S 24V DC IP 54 straight receptacle</p> <p>V2R 230V AC IP 54 angled rotatable receptacle</p> <p>V2S 230V AC IP 54 straight receptacle</p> |
| | | | | | <p>Certified execution</p> <p>(blank) CE</p> <p>CUS UL</p> | |
| | | | | <p>Brake/Flywheel</p> <p>(blank) no brake nor flywheel (default)</p> <p>F24 brake 24 Vdc</p> <p>F1 additional flywheel / inertia</p> | | |
| | | | <p>Signal connector</p> <p>(blank) Sensorless version, no feedback device</p> <p>S1 Angled rotatable receptacle, with plug</p> <p>S1N Angled rotatable receptacle, without plug</p> <p>S2 ⁽³⁾⁽⁵⁾ Cable with flying leads, without connector</p> <p>S2C ⁽³⁾⁽⁵⁾ Cable with SubD connector</p> <p>S3 Straight receptacle, with plug</p> <p>S3N Straight receptacle, without plug</p> | | | |
| | | | <p>Power connector</p> <p>P1 Angled rotatable receptacle, with plug</p> <p>P1N Angled rotatable receptacle, without plug</p> <p>P2 ⁽³⁾⁽⁵⁾ Cable with flying leads, without connector</p> <p>P3 Straight receptacle, with plug</p> <p>P3N ⁽³⁾ Straight receptacle, without plug</p> | | | |
| | <p>Feedback device</p> <p>RES1 ⁽³⁾ 2 poles resolver 8 kHz</p> <p>RES2 2 poles resolver 10 kHz</p> <p>ENB1 Optical absolute encoder EnDat interface Single Turn</p> <p>ENB2 Optical absolute encoder EnDat interface Multi Turn</p> <p>ENB3 Optical absolute encoder Hiperface interface Single Turn</p> <p>ENB4 Optical absolute encoder Hiperface interface Multi Turn</p> <p>ENB5 Capacitive absolute encoder Hiperface interface Single Turn</p> <p>ENB6 Capacitive absolute encoder Hiperface interface Multi Turn</p> <p>ENB7 ⁽³⁾ Optical SinCos absolute encoder Single Turn</p> <p>ENB8 Inductive absolute encoder EnDat interface Multi Turn</p> <p>SEN Sensorless</p> | | | | | |
| <p>Thermal protection</p> <p>PTC Thermistor PTC 150</p> <p>KTY Silicon sensor type KTY84-130</p> <p>TC1 Platinum sensor PT1000</p> | | | | | | |

Notes:

(1) M flange dimension, see page 16

(2) For available motor AC voltage and speed combinations refer to general overview of page 15

(3) Not available for motor size BMD 65

(4) For available motor AC voltage and speed combinations refer to page 51. Not compatible with UL certification (CUS option).

(5) Standard length 1 meter, for different lengths please contact us

Please check the compatibility with our Motion Control with our Technical team or by consulting the Motion Control catalogue.

Coupling dimensions

The coupling dimensions include both, flange and shaft that are univocally defined by catalogue variants. The flanges and the shafts of BMD are described by fixed geometrics according to standard IEC 60072-1.

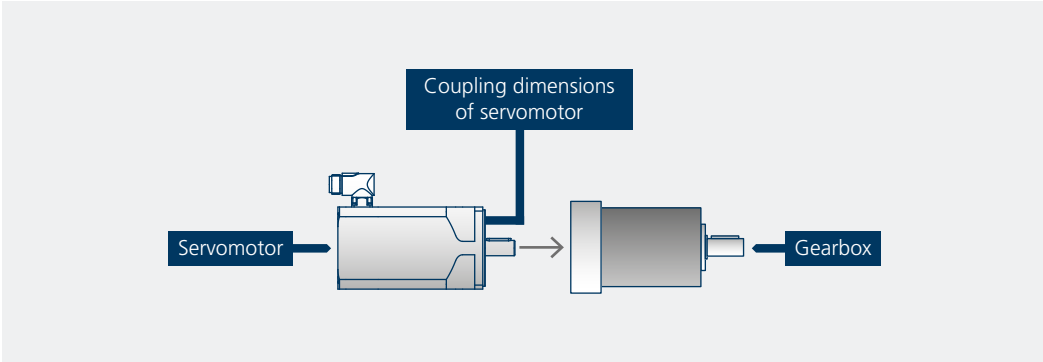

According to IEC 60072-1, the interface geometry is defined by quantities D, E, P, M, N, S showed in the following drawing whose numerical values (mm) depend on motor size.

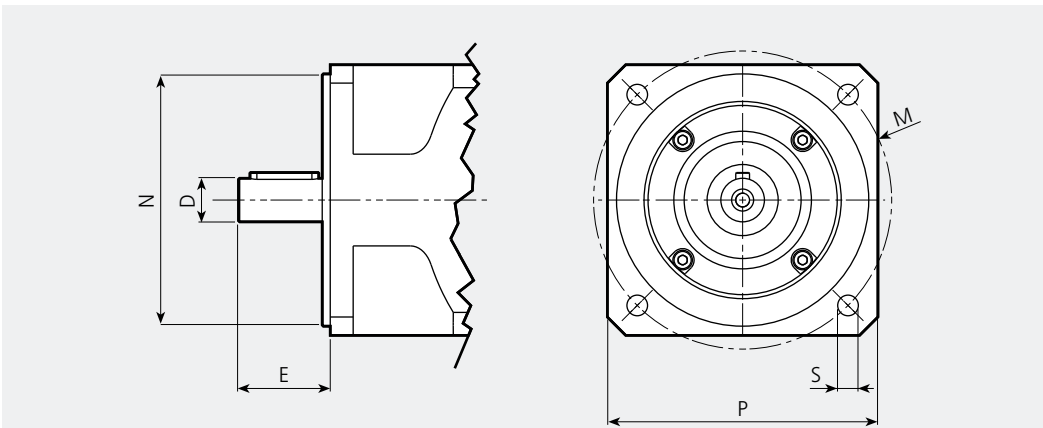

| SERVOMOTORS | | | | | | | | | | | | |
|-------------------------------|-----|---------------|-----|-------------------------|-----|----------------|-----|-------------------------|-----|-------------------------|-----|-------------------------|
| | | BMD65 | | BMD82 | | BMD102 | | BMD118 | | BMD145 | | BMD170 |
| Shaft diameter x shaft length | DxE | 9x20 11x23 | | 11x23 14x30 19x40 | | 19x40 24x50 | | 19x40 24x50 28x60 | | 19x40 24x50 28x60 | | 24x50 28x60 32x60 |
| Flange square | P | 65 | 65 | 82 | 100 | 102 | 102 | 118 | 118 | 145 | 145 | 170 |
| Flange pitch holes diameter | M | 63 | 75 | 100 | 115 | 100 | 115 | 130 ⁽¹⁾ | 130 | 165 | 165 | 165 |
| Diameter of the spigot | N | 40 | 60 | 80 | 95 | 80 | 95 | 95 | 110 | 130 | 130 | 130 |
| Fixing holes diameters | S | 5.8 | 5.8 | 6.5 | 9 | 7 | 9 | 9 | 9 | 12 | 12 | 12 |

Notes:
(1) Flange variant 130S

Mechanical tolerances

Dimensions and tolerances of shaft extension, key and flange are in accordance with IEC 60072-1.

Shaft extension features an axial threaded hole in accordance with UNI 3221, DIN 332.

Tolerances of the different parts are reported in the table.

| COMPONENT | | DIMENSIONS | TOLERANCE |
|-----------|---|------------|-----------|
| Shaft end | D | Ø 9 - 28 | j6 |
| | | Ø 32 | k6 |
| Key | F | | h9 |
| Flange | N | Ø < 250 | j6 |

Bearings

BMD motors use radial ball bearings, lubricated for life with grease and axially pre-loaded. The types of bearings in use are listed in the following table.

| SIZE | DRIVE END | NON DRIVE END |
|---------|-----------|---------------|
| BMD 65 | 6201 2RS | 6001 2RS |
| BMD 82 | 6205 2RS | 6203 2RS |
| BMD 102 | 6205 2RS | 6204 2RS |
| BMD 118 | 6206 2RS | 6205 2RS |
| BMD 145 | 6206 2RS | 6305 2RS |
| BMD 170 | 6208 2RS | 6305 2RS |

Shaft loads

The maximum radial load (F_R) and maximum axial load (F_A) are computed using ISO 281 calculation L_{10h} assuming a bearing life of 20.000h. The load and the speed are assumed to be constant throughout the bearing life.

The maximum radial load is reported as a function of the distance (X) between flange plane and the point of force application. The fatigue limit for the radial load is computed for each size assuming the smallest shaft diameter catalogue (e.g. 11mm for BMD 82). The maximum radial loads F_R are valid only for the horizontal installation of the motor without additional axial load.

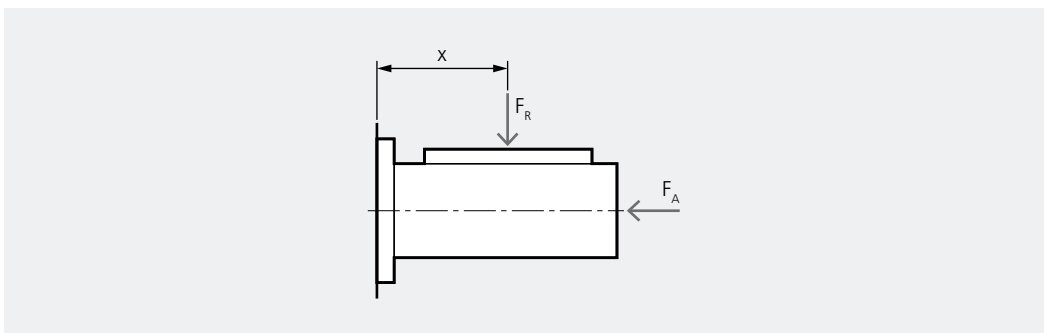

Maximum axial load ($F_R=0$)

| SIZE | SPEED [min ⁻¹] | | | | | |
|---------|----------------------------|------|------|------|------|------|
| | [Nm] | 1600 | 3000 | 4500 | 5500 | 6000 |
| BMD 65 | 0.85 | 59 | 48 | 42 | 39 | 38 |
| | 1.7 | 65 | 53 | 46 | 43 | 42 |
| | 2.2 | 69 | 56 | 49 | 46 | 44 |
| BMD 82 | 3.2 | 115 | 94 | 82 | 77 | 75 |
| | 4.4 | 120 | 100 | 85 | 81 | 79 |
| BMD 102 | 4 | 140 | 110 | 100 | 95 | 90 |
| | 7.2 | 150 | 120 | 105 | 100 | 95 |
| | 9.6 | 160 | 130 | 110 | 105 | 100 |
| BMD 118 | 5.6 | 150 | 132 | 114 | 109 | 104 |
| | 10.2 | 170 | 139 | 121 | 115 | 110 |
| | 14 | 180 | 145 | 130 | 120 | 115 |
| BMD 145 | 16.8 | 280 | 230 | 200 | 185 | 180 |
| | 22 | 295 | 240 | 210 | 195 | |
| BMD 170 | 34 | 300 | 270 | | | |
| | 45 | 320 | 290 | | | |

Shaft loads

Maximum radial load ($F_A=0$)

Curves parametrized according to motor nominal speed.

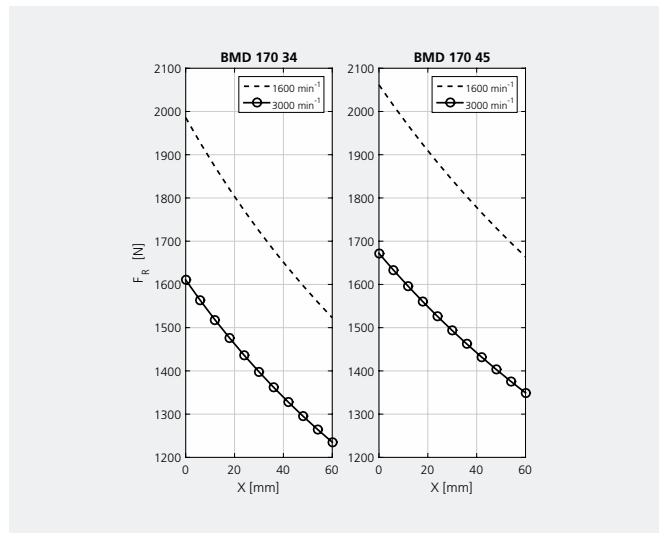
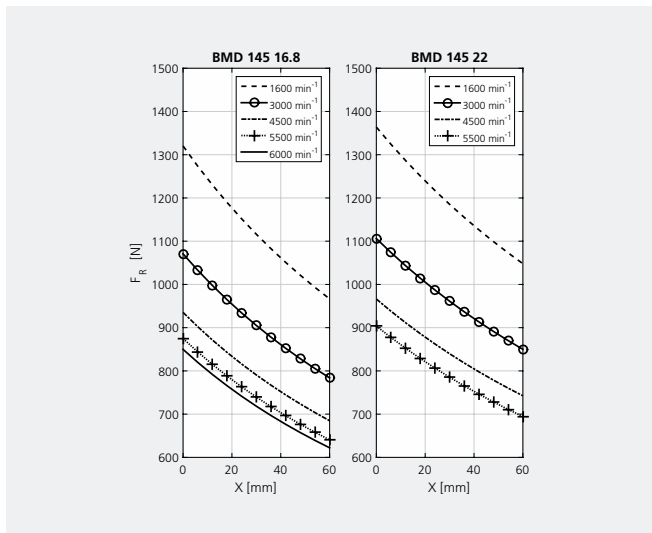
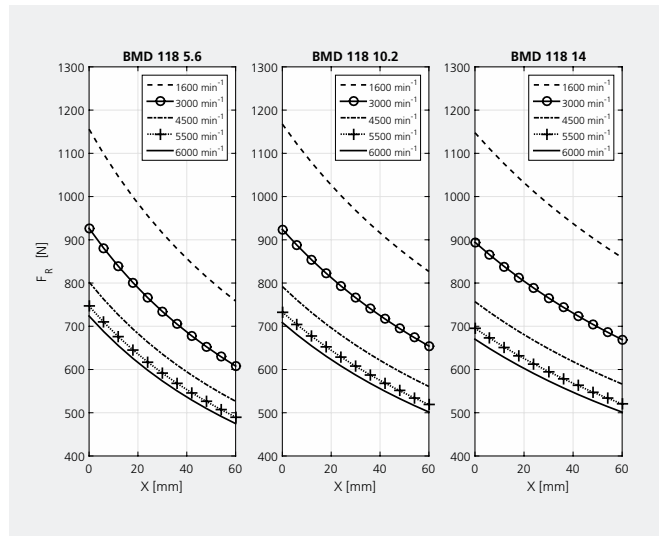
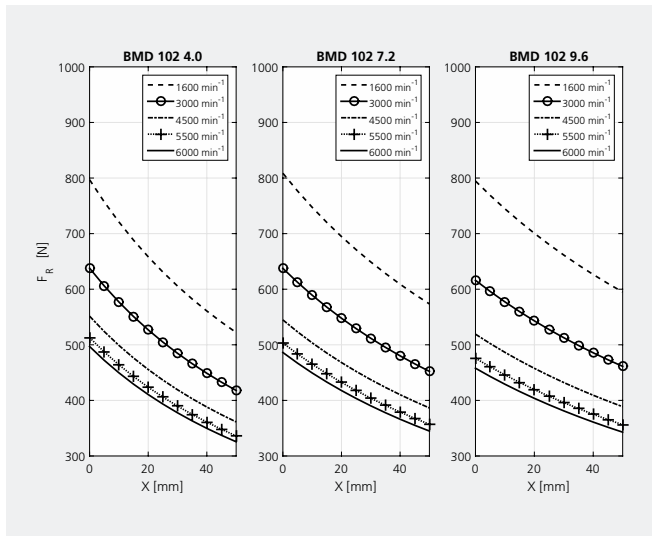
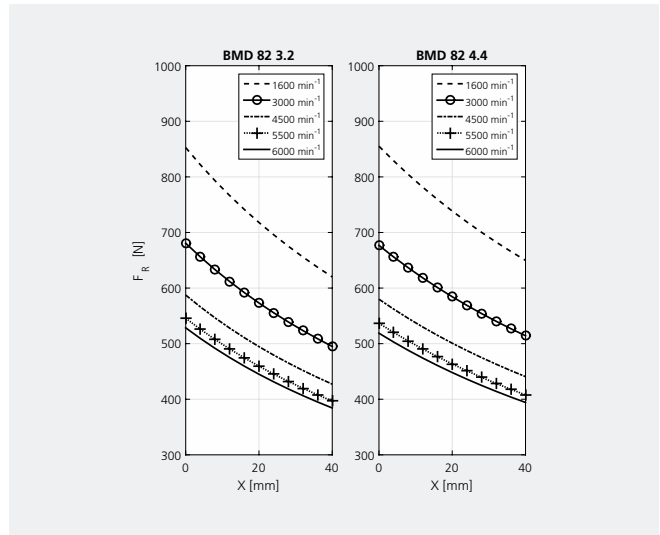
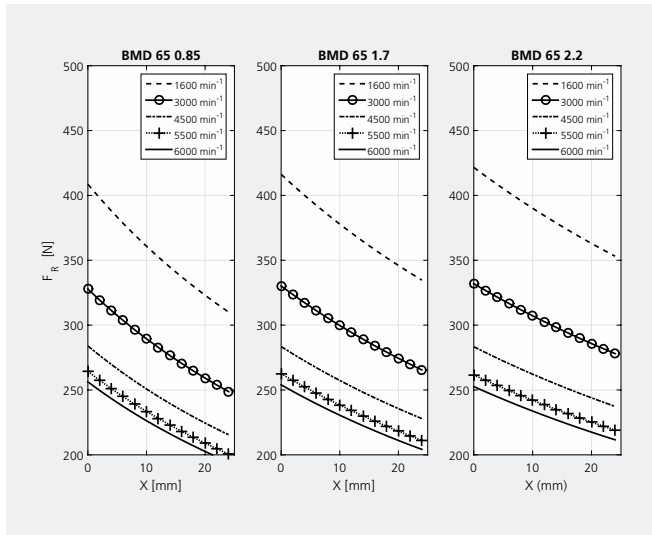

BMD 65 • Ratings

| | | BMD 65 0.85 Nm | | | | | BMD 65 1.7 Nm | | | | | BMD 65 2.2 Nm | | | | | |
|-----------|----------------|--------------------------------------|--------------------|------|------|------|---------------|------|------|------|------|---------------|------|------|------|------|------|
| | M_0 | [Nm] | 0.85 | | | | | 1.70 | | | | | 2.20 | | | | |
| | M_n | [Nm] | 0.83 | 0.80 | 0.76 | 0.74 | 0.73 | 1.65 | 1.60 | 1.52 | 1.48 | 1.45 | 2.12 | 2.05 | 1.95 | 1.85 | 1.80 |
| | n | [min ⁻¹] | 1600 | 3000 | 4500 | 5500 | 6000 | 1600 | 3000 | 4500 | 5500 | 6000 | 1600 | 3000 | 4500 | 5500 | 6000 |
| | f_n | [Hz] | 107 | 200 | 300 | 367 | 400 | 107 | 200 | 300 | 367 | 400 | 107 | 200 | 300 | 367 | 400 |
| | P_n | [kW] | 0.14 | 0.25 | 0.36 | 0.43 | 0.46 | 0.28 | 0.50 | 0.72 | 0.85 | 0.91 | 0.36 | 0.64 | 0.92 | 1.07 | 1.13 |
| | M_{max} | [Nm] | 2.55 | | | | | 4.90 | | | | | 6.20 | | | | |
| | $2p$ | [-] | 8 | | | | | 8 | | | | | 8 | | | | |
| | J | [Kg ^m ·10 ⁻⁴] | 0.2 | | | | | 0.4 | | | | | 0.6 | | | | |
| | τ_{el} | [ms] | 3 | | | | | 3 | | | | | 3 | | | | |
| | τ_{therm} | [min] | 14 | | | | | 20 | | | | | 26 | | | | |
| | m_M | [kg] | 1.3 | | | | | 1.9 | | | | | 2.6 | | | | |
| | 230 Vac | V_n | [V _{AC}] | 168 | 181 | 172 | 179 | 177 | 193 | 180 | 180 | 174 | 171 | 179 | 180 | 191 | 192 |
| I_0 | | [A] | 0.77 | 1.23 | 1.93 | 2.18 | 2.39 | 1.26 | 2.34 | 3.40 | 4.20 | 4.70 | 1.70 | 2.96 | 4.10 | 4.90 | 5.40 |
| I_n | | [A] | 0.74 | 1.16 | 1.74 | 1.92 | 2.09 | 1.25 | 2.30 | 3.20 | 3.90 | 4.20 | 1.65 | 2.78 | 3.60 | 4.10 | 4.40 |
| I_{max} | | [A] | 2.50 | 3.90 | 6.20 | 7.00 | 7.70 | 4.30 | 8.00 | 11.5 | 14.5 | 15.9 | 5.40 | 9.40 | 12.9 | 15.6 | 17.1 |
| K_e | | [mV/min ⁻¹] | 75 | 47 | 30 | 27 | 24 | 89 | 48 | 33 | 26 | 24 | 90 | 52 | 38 | 31 | 28 |
| K_T | | [Nm/A] | 1.10 | 0.69 | 0.44 | 0.39 | 0.36 | 1.35 | 0.73 | 0.50 | 0.40 | 0.36 | 1.29 | 0.74 | 0.54 | 0.45 | 0.41 |
| R_{pp} | | [Ω] | 48.4 | 19.2 | 7.75 | 6.10 | 5.04 | 30.4 | 8.79 | 4.19 | 2.66 | 2.20 | 18.8 | 6.21 | 3.27 | 2.26 | 1.86 |
| L_{pp} | | [mH] | 145 | 57.5 | 23.2 | 18.3 | 15.1 | 91.9 | 26.6 | 12.6 | 8.00 | 6.60 | 56.9 | 18.8 | 9.90 | 6.80 | 5.60 |
| 400 Vac | V_n | [V _{AC}] | - | 295 | 331 | 318 | 306 | 336 | 311 | 308 | 316 | 300 | 285 | 314 | 314 | 328 | 313 |
| | I_0 | [A] | - | 0.76 | 0.98 | 1.23 | 1.38 | 0.72 | 1.35 | 1.98 | 2.34 | 2.68 | 1.07 | 1.70 | 2.48 | 2.88 | 3.27 |
| | I_n | [A] | - | 0.72 | 0.88 | 1.08 | 1.21 | 0.72 | 1.33 | 1.85 | 2.14 | 2.43 | 1.04 | 1.60 | 2.20 | 2.41 | 2.68 |
| | I_{max} | [A] | - | 2.43 | 3.10 | 3.90 | 4.40 | 2.46 | 4.60 | 6.70 | 8.00 | 9.10 | 3.40 | 5.40 | 7.90 | 9.10 | 10.4 |
| | K_e | [mV/min ⁻¹] | - | 76 | 59 | 47 | 42 | 155 | 83 | 57 | 48 | 42 | 143 | 90 | 62 | 53 | 47 |
| | K_T | [Nm/A] | - | 1.12 | 0.87 | 0.69 | 0.62 | 2.36 | 1.26 | 0.86 | 0.73 | 0.63 | 2.06 | 1.29 | 0.89 | 0.76 | 0.67 |
| | R_{pp} | [Ω] | - | 50.0 | 30.3 | 19.2 | 15.1 | 92.3 | 26.3 | 12.2 | 8.79 | 6.65 | 47.6 | 18.8 | 8.82 | 6.56 | 5.08 |
| | L_{pp} | [mH] | - | 150 | 90.7 | 57.5 | 45.2 | 279 | 79.5 | 37.0 | 26.6 | 20.1 | 144 | 56.9 | 26.7 | 19.8 | 15.4 |
| F24 | M_b | [Nm] | 2 | | | | | 2 | | | | | 2 | | | | |
| | Δm_M | [kg] | 0.2 | | | | | 0.2 | | | | | 0.2 | | | | |
| | ΔJ | [Kg ^m ·10 ⁻⁴] | 0.1 | | | | | 0.1 | | | | | 0.1 | | | | |
| F1 | Δm_M | [kg] | 0.4 | | | | | 0.4 | | | | | 0.4 | | | | |
| | ΔJ | [Kg ^m ·10 ⁻⁴] | 0.5 | | | | | 0.5 | | | | | 0.5 | | | | |

BMD 65 • Dimensions

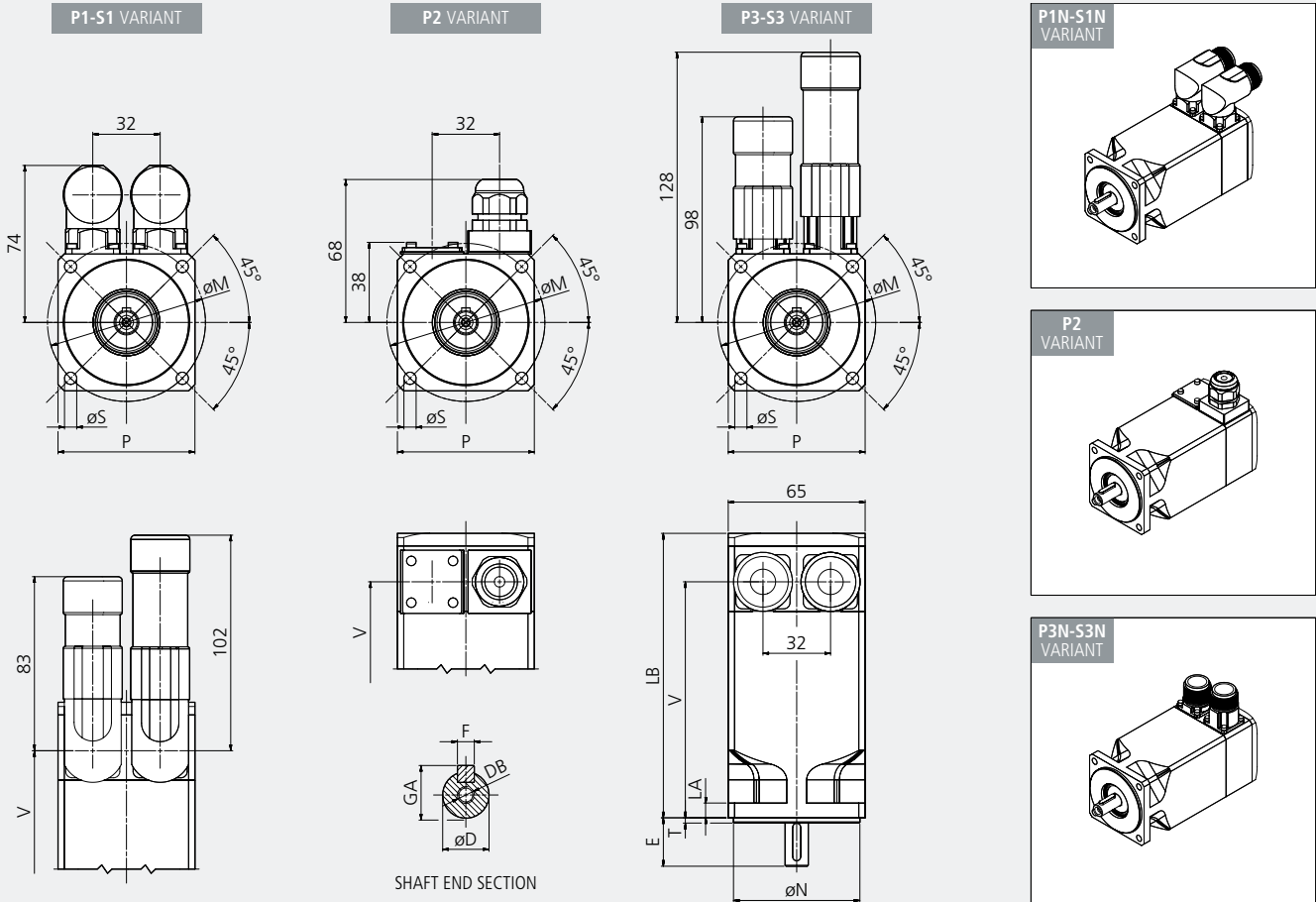

| B5 FLANGE VARIANT | | | | | | |
|-------------------|----|----|----|-----|-----|----|
| Flange variant | P | M | N | S | T | LA |
| 63 | 65 | 63 | 40 | 5.8 | 2.5 | 7 |
| 75 | 65 | 75 | 60 | 5.8 | 2.5 | 7 |

| SHAFT DIAMETER VARIANT | | | | | |
|------------------------|----|----|----|-------------------|------------------|
| Shaft diameter | D | E | DB | GA ⁽¹⁾ | F ⁽¹⁾ |
| 9 | 9 | 20 | M3 | 10.2 | 3 |
| 11 | 11 | 23 | M4 | 12.5 | 4 |

MOTOR LENGTH DEPENDING ON THE OPTION

| DIMENSION V | | | | | | | |
|-------------|---------------------------|-----------|------------------|---------------------------------------|-----------|------------------|--|
| Torque | Without Brake or Flywheel | | | With Brake or Flywheel F24/F1 options | | | |
| | Feedback Variants | | | Feedback Variants | | | |
| M_0 | RES2/SEN | ENB1/ENB2 | ENB3...ENB6/ENB8 | RES2/SEN | ENB1/ENB2 | ENB3...ENB6/ENB8 | |
| 0,85 | 89 | 89 | 89 | 89 | 138 | 138 | |
| 1,7 | 112 | 112 | 112 | 112 | 161 | 161 | |
| 2,2 | 138 | 138 | 138 | 138 | 187 | 187 | |

| DIMENSION LB | | | | | | | |
|--------------|---------------------------|-----------|------------------|---------------------------------------|-------------|------|--|
| Torque | Without Brake or Flywheel | | | With Brake or Flywheel F24/F1 options | | | |
| | Feedback Variants | | | Feedback Variants | | | |
| M_0 | RES2/SEN | ENB1/ENB2 | ENB3...ENB6/ENB8 | RES2/SEN | ENB1...ENB6 | ENB8 | |
| 0,85 | 112 | 130 | 130 | 143 | 179 | 161 | |
| 1,7 | 135 | 153 | 153 | 166 | 202 | 184 | |
| 2,2 | 161 | 179 | 179 | 192 | 228 | 210 | |

Notes:
 (1) Motor shaft extension without key available.

BMD 82 • Ratings

| | | BMD 82 3.2 Nm | | | | | BMD 82 4.4 Nm | | | | | |
|---------|----------------|---------------------------------------|------|------|------|------|---------------|------|------|------|------|------|
| | M_0 | [Nm] | 3.20 | | | | | 4.40 | | | | |
| | M_n | [Nm] | 3.15 | 3.00 | 2.80 | 2.60 | 2.50 | 4.20 | 3.80 | 3.55 | 3.30 | 3.15 |
| | n | [min ⁻¹] | 1600 | 3000 | 4500 | 5500 | 6000 | 1600 | 3000 | 4500 | 5500 | 6000 |
| | f_n | [Hz] | 107 | 200 | 300 | 367 | 400 | 107 | 200 | 300 | 367 | 400 |
| | P_n | [kW] | 0.53 | 0.94 | 1.32 | 1.50 | 1.57 | 0.70 | 1.19 | 1.67 | 1.90 | 2.00 |
| | M_{max} | [Nm] | 8.50 | | | | | 11.5 | | | | |
| | $2p$ | [-] | 8 | | | | | 8 | | | | |
| | J | [Kgm ² ·10 ⁻⁴] | 1.4 | | | | | 1.7 | | | | |
| | τ_{el} | [ms] | 5.7 | | | | | 5.7 | | | | |
| | τ_{therm} | [min] | 26 | | | | | 33 | | | | |
| | m_M | [kg] | 3.5 | | | | | 4.6 | | | | |
| 230 Vac | V_n | [V _{AC}] | 191 | 181 | 200 | 176 | 176 | 181 | 184 | 188 | 196 | 197 |
| | I_0 | [A] | 2.51 | 4.50 | 6.00 | 8.30 | 9.00 | 3.30 | 5.80 | 8.40 | 9.70 | 10.6 |
| | I_n | [A] | 2.37 | 4.30 | 5.30 | 7.00 | 7.60 | 3.10 | 5.10 | 6.80 | 7.30 | 7.60 |
| | I_{max} | [A] | 8.30 | 15.5 | 20.6 | 15.5 | 8.30 | 9.80 | 17.4 | 25.1 | 29.2 | 32.0 |
| | K_e | [mV/min ⁻¹] | 92 | 49 | 37 | 27 | 24 | 93 | 52 | 36 | 31 | 29 |
| | K_T | [Nm/A] | 1.33 | 0.71 | 0.53 | 0.39 | 0.35 | 1.35 | 0.76 | 0.53 | 0.45 | 0.42 |
| | R_{pp} | [Ω] | 11.3 | 3.23 | 1.81 | 0.96 | 0.81 | 6.89 | 2.19 | 1.05 | 0.78 | 0.66 |
| | L_{pp} | [mH] | 64.2 | 18.3 | 10.3 | 5.40 | 4.60 | 39.0 | 12.4 | 6.00 | 4.40 | 3.70 |
| 400 Vac | V_n | [V _{AC}] | 332 | 315 | 312 | 323 | 308 | 315 | 323 | 328 | 335 | 335 |
| | I_0 | [A] | 1.39 | 2.60 | 3.90 | 4.50 | 5.20 | 1.88 | 3.30 | 4.80 | 5.70 | 6.20 |
| | I_n | [A] | 1.36 | 2.50 | 3.40 | 3.80 | 4.30 | 1.76 | 2.90 | 3.90 | 4.30 | 4.50 |
| | I_{max} | [A] | 4.70 | 8.90 | 13.2 | 15.5 | 17.7 | 5.60 | 9.90 | 14.4 | 17.1 | 18.6 |
| | K_e | [mV/min ⁻¹] | 159 | 85 | 57 | 49 | 43 | 161 | 92 | 63 | 53 | 49 |
| | K_T | [Nm/A] | 2.31 | 1.23 | 0.83 | 0.71 | 0.62 | 2.34 | 1.33 | 0.92 | 0.77 | 0.71 |
| | R_{pp} | [Ω] | 34.3 | 9.75 | 4.42 | 3.23 | 2.47 | 20.8 | 6.77 | 3.21 | 2.26 | 1.92 |
| | L_{pp} | [mH] | 194 | 55.2 | 25.0 | 18.3 | 14.0 | 118 | 38.3 | 18.1 | 12.8 | 10.8 |
| F24 | M_b | [Nm] | 4.5 | | | | | 4.5 | | | | |
| | Δm_M | [kg] | 0.6 | | | | | 0.6 | | | | |
| | ΔJ | [Kgm ² ·10 ⁻⁴] | 0.2 | | | | | 0.2 | | | | |
| F1 | Δm_M | [kg] | 1 | | | | | 1 | | | | |
| | ΔJ | [Kgm ² ·10 ⁻⁴] | 3 | | | | | 3 | | | | |

BMD 82 • Dimensions

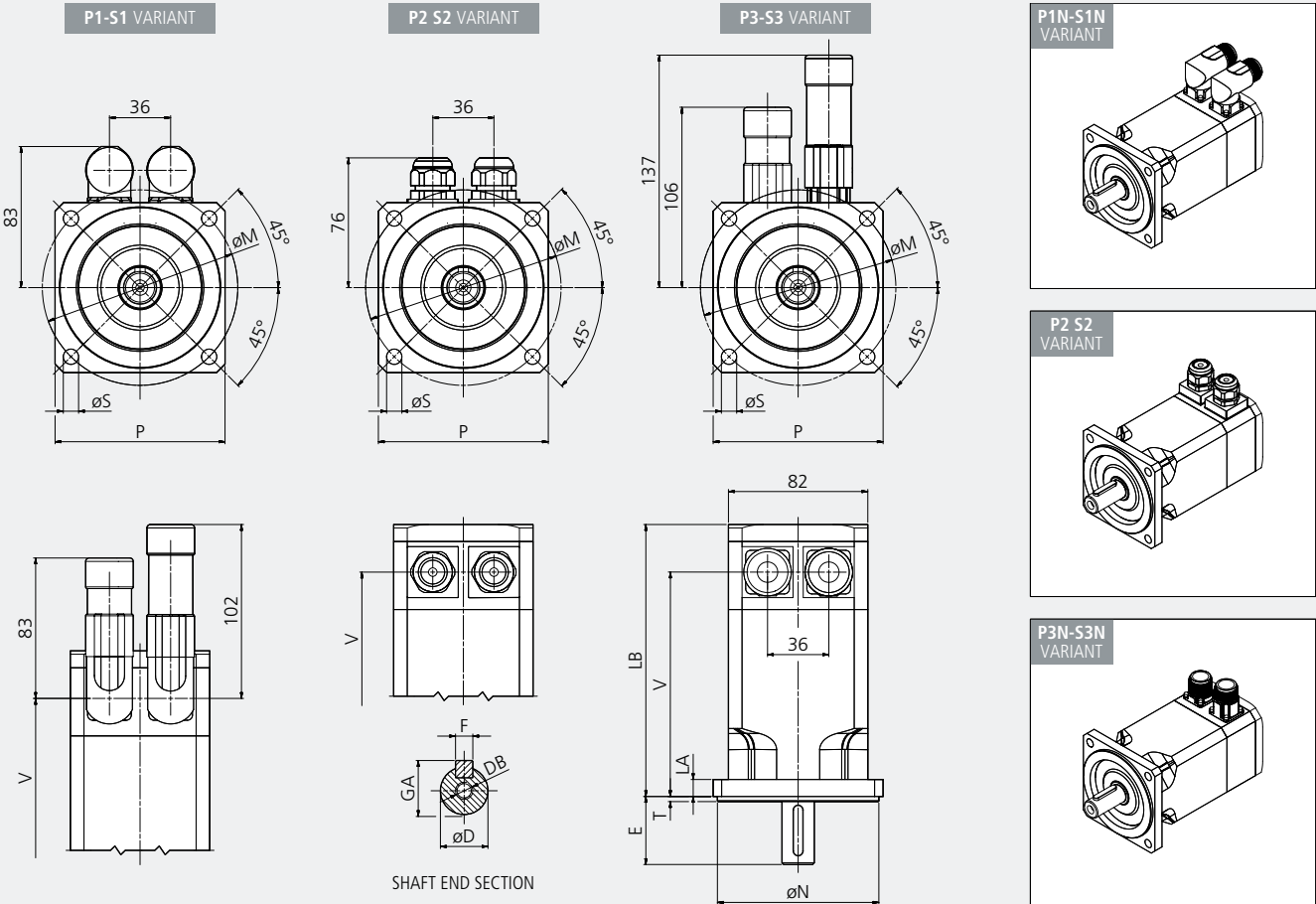

| B5 FLANGE VARIANT | | | | | | |
|-------------------|-----|-----|----|-----|---|----|
| Flange variant | P | M | N | S | T | LA |
| 100 | 82 | 100 | 80 | 6.5 | 3 | 10 |
| 115 | 100 | 115 | 95 | 9 | 3 | 10 |

| SHAFT DIAMETER VARIANT | | | | | |
|------------------------|----|----|----|-------------------|------------------|
| Shaft diameter | D | E | DB | GA ⁽¹⁾ | F ⁽¹⁾ |
| 11 | 11 | 23 | M4 | 12.5 | 4 |
| 14 | 14 | 30 | M5 | 16 | 5 |
| 19 | 19 | 40 | M6 | 21.5 | 6 |

MOTOR LENGTH DEPENDING ON THE OPTION

| DIMENSION V | | | | | | | |
|----------------------|---------------------------|-----------------------|-------------------------|---------------------------------------|----------------------------|--------------------|--|
| Torque | Without Brake or Flywheel | | | With Brake or Flywheel F24/F1 options | | | |
| | Feedback Variants | | | Feedback Variants | | | |
| M₀ | RES1/RES2/SEN | ENB1/ENB2/ENB7 | ENB3...ENB6/ENB8 | RES1/RES2/SEN | ENB1/ENB2/ENB7/ENB8 | ENB3...ENB6 | |
| 3.2 | 132 | 132 | 132 | 132 | 195 | 218 | |
| 4.4 | 152 | 152 | 152 | 152 | 215 | 238 | |

| DIMENSION LB | | | | | | |
|----------------------|---------------------------|-----------------------|-------------------------|---------------------------------------|--------------------|-------------|
| Torque | Without Brake or Flywheel | | | With Brake or Flywheel F24/F1 options | | |
| | Feedback Variants | | | Feedback Variants | | |
| M₀ | RES1/RES2/SEN | ENB1/ENB2/ENB7 | ENB3...ENB6/ENB8 | RES1/RES2/SEN | ENB1...ENB7 | ENB8 |
| 3.2 | 160 | 183 | 160 | 200 | 223 | 200 |
| 4.4 | 180 | 203 | 180 | 220 | 243 | 220 |

Notes:
 (1) Motor shaft extension without key available.

BMD 102 • Ratings

| | | BMD 102 4 Nm | | | | | BMD 102 7.2 Nm | | | | | BMD 102 9.6 Nm | | | | | | |
|-----------|----------------|--------------------------------------|--------------------|------|------|------|----------------|------|------|------|------|----------------|------|------|------|------|------|------|
| | M_0 | [Nm] | 4.00 | | | | | 7.20 | | | | | 9.60 | | | | | |
| | M_n | [Nm] | 3.70 | 3.40 | 3.10 | 2.90 | 2.80 | 7.00 | 6.70 | 6.00 | 5.80 | 5.60 | 9.20 | 8.50 | 7.70 | 6.90 | 6.50 | |
| | n | [min ⁻¹] | 1600 | 3000 | 4500 | 5500 | 6000 | 1600 | 3000 | 4500 | 5500 | 6000 | 1600 | 3000 | 4500 | 5500 | 6000 | |
| | f_n | [Hz] | 107 | 200 | 300 | 367 | 400 | 107 | 200 | 300 | 367 | 400 | 107 | 200 | 300 | 367 | 400 | |
| | P_n | [kW] | 0.62 | 1.01 | 1.46 | 1.67 | 1.76 | 1.17 | 2.10 | 2.83 | 3.30 | 3.50 | 1.54 | 2.70 | 3.60 | 4.00 | 4.10 | |
| | M_{max} | [Nm] | 11.0 | | | | | 21.0 | | | | | 28.0 | | | | | |
| | $2p$ | [-] | 8 | | | | | 8 | | | | | 8 | | | | | |
| | J | [Kg ^m ·10 ⁻⁴] | 1.9 | | | | | 3.4 | | | | | 4.7 | | | | | |
| | τ_{el} | [ms] | 8.4 | | | | | 8.4 | | | | | 8.4 | | | | | |
| | τ_{therm} | [min] | 25 | | | | | 31 | | | | | 38 | | | | | |
| | m_M | [kg] | 4.2 | | | | | 5.8 | | | | | 7.4 | | | | | |
| | 230 Vac | V_n | [V _{AC}] | 184 | 177 | 177 | 181 | 174 | 187 | 177 | 182 | 183 | 185 | 183 | 184 | 187 | 192 | 190 |
| | | I_0 | [A] | 3.03 | 5.73 | 8.82 | 10.0 | 11.4 | 5.00 | 9.70 | 13.9 | 16.9 | 18.2 | 6.30 | 11.5 | 16.8 | 19.8 | 21.8 |
| I_n | | [A] | 2.60 | 4.86 | 6.88 | 7.40 | 8.29 | 4.90 | 9.50 | 12.6 | 14.4 | 15.4 | 6.00 | 10.2 | 13.5 | 14.3 | 14.8 | |
| I_{max} | | [A] | 9.30 | 17.6 | 27.3 | 30.7 | 35.1 | 18.3 | 35.0 | 51.0 | 61.0 | 66.0 | 20.4 | 37.0 | 54.0 | 64.0 | 70.0 | |
| K_e | | [mV/min ⁻¹] | 94 | 50 | 32 | 28 | 25 | 94 | 49 | 34 | 28 | 26 | 102 | 56 | 38 | 33 | 30 | |
| K_T | | [Nm/A] | 1.32 | 0.70 | 0.45 | 0.40 | 0.35 | 1.43 | 0.75 | 0.52 | 0.43 | 0.40 | 1.52 | 0.84 | 0.57 | 0.48 | 0.44 | |
| R_{pp} | | [Ω] | 8.38 | 2.39 | 1.02 | 0.76 | 0.59 | 3.02 | 0.82 | 0.40 | 0.27 | 0.23 | 2.24 | 0.68 | 0.32 | 0.23 | 0.19 | |
| L_{pp} | | [mH] | 70.5 | 20.1 | 8.58 | 6.40 | 4.96 | 25.4 | 6.90 | 3.30 | 2.30 | 1.90 | 18.8 | 5.70 | 2.70 | 1.90 | 1.60 | |
| 400 Vac | V_n | [V _{AC}] | 314 | 305 | 303 | 319 | 314 | 320 | 311 | 305 | 320 | 305 | 318 | 324 | 323 | 332 | 333 | |
| | I_0 | [A] | 1.77 | 3.30 | 4.90 | 5.68 | 6.30 | 2.94 | 5.50 | 8.30 | 9.70 | 11.0 | 3.60 | 6.50 | 9.70 | 11.5 | 12.4 | |
| | I_n | [A] | 1.52 | 2.83 | 3.80 | 4.20 | 4.60 | 2.92 | 5.40 | 7.50 | 8.20 | 9.30 | 3.40 | 5.80 | 7.80 | 8.30 | 8.40 | |
| | I_{max} | [A] | 5.48 | 10.2 | 15.0 | 17.6 | 19.0 | 10.7 | 20.0 | 30.0 | 35.0 | 40.0 | 11.7 | 21.0 | 31.0 | 37.0 | 40.0 | |
| | K_e | [mV/min ⁻¹] | 160 | 86 | 57 | 49 | 43 | 161 | 86 | 57 | 49 | 43 | 177 | 99 | 66 | 56 | 52 | |
| | K_T | [Nm/A] | 2.26 | 1.21 | 0.82 | 0.70 | 0.63 | 2.45 | 1.31 | 0.87 | 0.75 | 0.65 | 2.65 | 1.48 | 0.99 | 0.84 | 0.77 | |
| | R_{pp} | [Ω] | 24.0 | 7.05 | 3.27 | 2.39 | 2.00 | 8.87 | 2.53 | 1.11 | 0.82 | 0.63 | 6.77 | 2.11 | 0.95 | 0.68 | 0.58 | |
| | L_{pp} | [mH] | 202 | 59.3 | 27.5 | 20.1 | 16.8 | 74.7 | 21.3 | 9.40 | 6.90 | 5.30 | 56.8 | 17.7 | 8.00 | 5.70 | 4.80 | |
| F24 | M_b | [Nm] | 9 | | | | | 9 | | | | | 9 | | | | | |
| | Δm_M | [kg] | 1.1 | | | | | 1.1 | | | | | 1.1 | | | | | |
| | ΔJ | [Kg ^m ·10 ⁻⁴] | 0.5 | | | | | 0.5 | | | | | 0.5 | | | | | |
| F1 | Δm_M | [kg] | 1.7 | | | | | 1.7 | | | | | 1.7 | | | | | |
| | ΔJ | [Kg ^m ·10 ⁻⁴] | 7.5 | | | | | 7.5 | | | | | 7.5 | | | | | |

BMD 102 • Dimensions

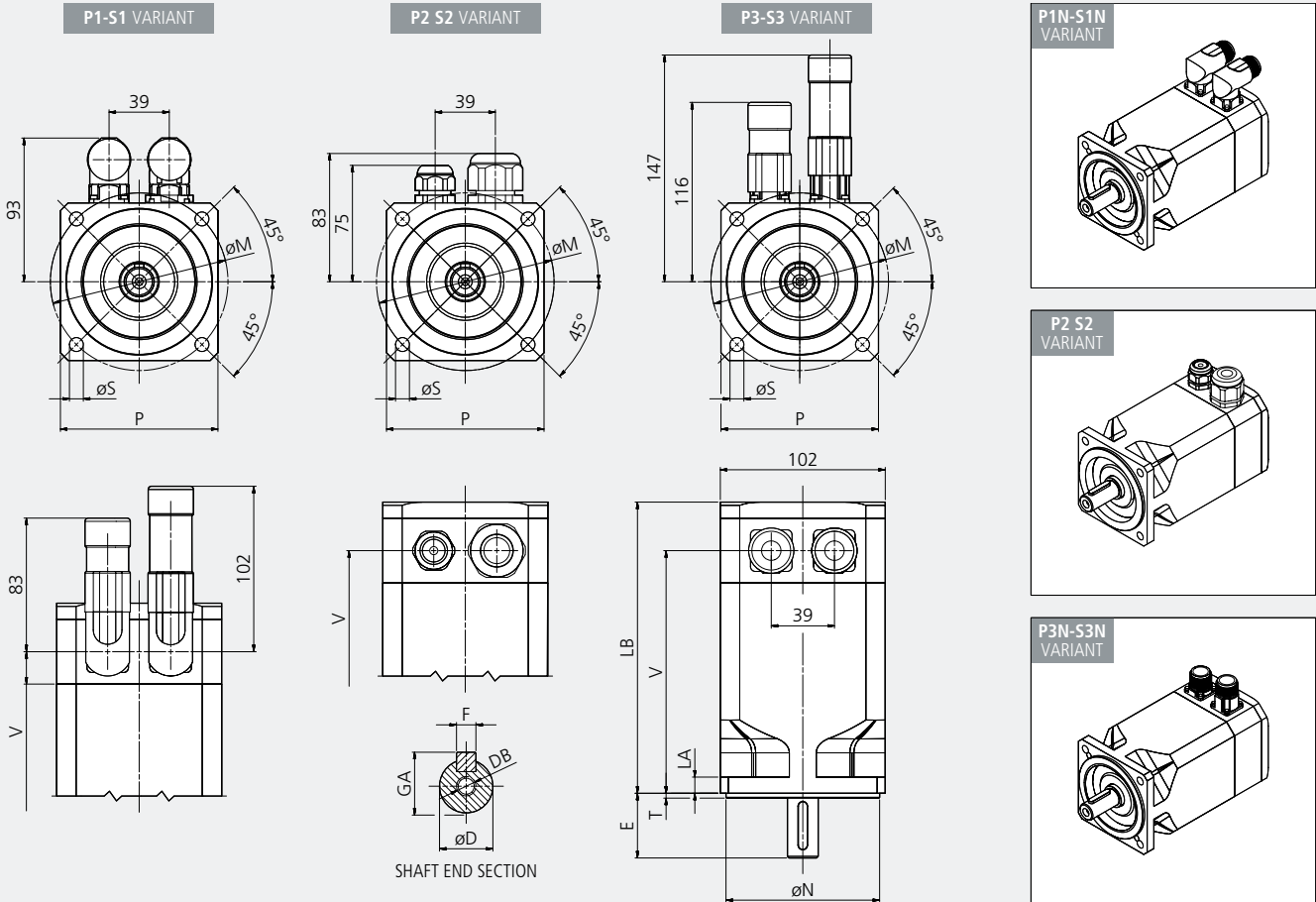

| B5 FLANGE VARIANT | | | | | | |
|-------------------|-----|-----|----|---|---|----|
| Flange variant | P | M | N | S | T | LA |
| 100 | 102 | 100 | 80 | 7 | 3 | 10 |
| 115 | 102 | 115 | 95 | 9 | 3 | 10 |

| SHAFT DIAMETER VARIANT | | | | | |
|------------------------|----|----|----|-------------------|------------------|
| Shaft diameter | D | E | DB | GA ⁽¹⁾ | F ⁽¹⁾ |
| 19 | 19 | 40 | M6 | 21.5 | 6 |
| 24 | 24 | 50 | M8 | 27 | 8 |

MOTOR LENGTH DEPENDING ON THE OPTION

| DIMENSION V | | | | | | | |
|----------------------|---------------------------|-----------------------|-------------------------|---------------------------------------|-----------------------|-------------------------|--|
| Torque | Without Brake or Flywheel | | | With Brake or Flywheel F24/F1 options | | | |
| | Feedback Variants | | | Feedback Variants | | | |
| M₀ | RES1/RES2/SEN | ENB1/ENB2/ENB7 | ENB3...ENB6/ENB8 | RES1/RES2/SEN | ENB1/ENB2/ENB7 | ENB3...ENB6/ENB8 | |
| 4 | 123 | 123 | 123 | 123 | 163 | 163 | |
| 16 | 150 | 150 | 150 | 150 | 190 | 190 | |
| 9.6 | 177 | 177 | 177 | 177 | 217 | 217 | |

| DIMENSION LB | | | | | | | |
|----------------------|---------------------------|-----------------------|-------------------------|---------------------------------------|-----------------------|-------------------------|--|
| Torque | Without Brake or Flywheel | | | With Brake or Flywheel F24/F1 options | | | |
| | Feedback Variants | | | Feedback Variants | | | |
| M₀ | RES1/RES2/SEN | ENB1/ENB2/ENB7 | ENB3...ENB6/ENB8 | RES1/RES2/SEN | ENB1/ENB2/ENB7 | ENB3...ENB6/ENB8 | |
| 4 | 153 | 176 | 153 | 193 | 216 | 193 | |
| 7.2 | 180 | 203 | 180 | 220 | 243 | 220 | |
| 9.6 | 207 | 230 | 207 | 247 | 297 | 247 | |

Notes:
 (1) Motor shaft extension without key available.

BMD 118 • Ratings

| | | BMD 118 5.6 Nm | | | | | BMD 118 10.2 Nm | | | | | BMD 118 14 Nm | | | | | |
|----------------|--------------------------------------|--------------------------------------|------|------|------|------|-----------------|------|------|------|------|---------------|------|------|------|------|------|
| M_0 | [Nm] | 5.60 | | | | | 10.2 | | | | | 14.0 | | | | | |
| M_n | [Nm] | 5.50 | 5.10 | 4.60 | 4.10 | 3.90 | 10.0 | 9.50 | 8.50 | 8.00 | 7.50 | 13.3 | 12.2 | 10.9 | 9.70 | 9.00 | |
| n | [min ⁻¹] | 1600 | 3000 | 4500 | 5500 | 6000 | 1600 | 3000 | 4500 | 5500 | 6000 | 1600 | 3000 | 4500 | 5500 | 6000 | |
| f_n | [Hz] | 107 | 200 | 300 | 367 | 400 | 107 | 200 | 300 | 367 | 400 | 107 | 200 | 300 | 367 | 400 | |
| P_n | [kW] | 0.92 | 1.60 | 2.18 | 2.36 | 2.45 | 1.68 | 3.00 | 4.00 | 4.60 | 4.70 | 2.20 | 3.80 | 5.00 | 5.30 | 5.30 | |
| M_{max} | [Nm] | 15.0 | | | | | 30.0 | | | | | 39.0 | | | | | |
| $2p$ | [-] | 8 | | | | | 8 | | | | | 8 | | | | | |
| J | [Kg ^m ·10 ⁻⁴] | 4.5 | | | | | 7.8 | | | | | 9.9 | | | | | |
| τ_{el} | [ms] | 13 | | | | | 13 | | | | | 13 | | | | | |
| τ_{therm} | [min] | 28 | | | | | 34 | | | | | 42 | | | | | |
| m_M | [kg] | 7.7 | | | | | 9.7 | | | | | 11.7 | | | | | |
| 230 Vac | V_n | [V _{AC}] | 179 | 185 | 180 | 186 | 171 | 184 | 178 | 174 | 196 | - | 184 | 192 | - | - | - |
| | I_0 | [A] | 4.20 | 7.30 | 11.2 | 13.2 | 15.6 | 7.20 | 13.7 | 20.8 | 22.6 | - | 9.20 | 16.3 | - | - | - |
| | I_n | [A] | 38.0 | 6.60 | 9.00 | 9.30 | 10.3 | 7.20 | 13.5 | 18.3 | 17.4 | - | 8.60 | 14.0 | - | - | - |
| | I_{max} | [A] | 13.8 | 23.9 | 36.5 | 43.0 | 50.8 | 25.3 | 48.0 | 73.0 | 79.0 | - | 30.0 | 53.0 | - | - | - |
| | K_e | [mV/min ⁻¹] | 92 | 52 | 34 | 28 | 24 | 95 | 50 | 33.1 | 30.4 | - | 104 | 59 | - | - | - |
| | K_T | [Nm/A] | 1.33 | 0.76 | 0.50 | 0.42 | 0.36 | 1.41 | 0.75 | 0.49 | 0.45 | - | 1.51 | 0.86 | - | - | - |
| | R_{pp} | [Ω] | 3.94 | 1.29 | 0.56 | 0.39 | 0.28 | 1.56 | 0.43 | 0.19 | 0.16 | - | 1.17 | 0.37 | - | - | - |
| | L_{pp} | [mH] | 52.3 | 17.1 | 7.40 | 5.18 | 3.72 | 20.5 | 5.70 | 2.50 | 2.10 | - | 15.4 | 4.90 | - | - | - |
| 400 Vac | V_n | [V _{AC}] | 322 | 315 | 316 | 335 | 324 | 312 | 305 | 314 | 323 | 306 | 323 | 320 | 325 | 335 | 329 |
| | I_0 | [A] | 2.30 | 4.30 | 6.40 | 7.30 | 8.20 | 4.30 | 8.00 | 11.6 | 13.7 | 15.8 | 5.30 | 9.80 | 14.4 | 16.9 | 18.9 |
| | I_n | [A] | 2.1 | 3.90 | 5.20 | 5.20 | 5.50 | 4.20 | 7.90 | 10.2 | 10.5 | 11.4 | 4.90 | 8.40 | 10.9 | 11.4 | 11.8 |
| | I_{max} | [A] | 7.49 | 14.0 | 21.0 | 24.0 | 27.0 | 14.9 | 28.0 | 40.0 | 48.0 | 55.0 | 17.2 | 32.0 | 47.0 | 55.0 | 62.0 |
| | K_e | [mV/min ⁻¹] | 165 | 88 | 59 | 52 | 46 | 161 | 86 | 60 | 50 | 44 | 182 | 98 | 67 | 57 | 51 |
| | K_T | [Nm/A] | 2.43 | 1.30 | 0.88 | 0.77 | 0.68 | 2.39 | 1.28 | 0.88 | 0.75 | 0.65 | 2.66 | 1.43 | 0.97 | 0.83 | 0.74 |
| | R_{pp} | [Ω] | 13.1 | 3.76 | 1.76 | 1.29 | 1.04 | 4.47 | 1.27 | 0.61 | 0.43 | 0.33 | 3.60 | 1.04 | 0.48 | 0.35 | 0.28 |
| | L_{pp} | [mH] | 174 | 50.5 | 23.4 | 17.1 | 13.8 | 58.8 | 16.7 | 8.00 | 5.70 | 4.30 | 47.4 | 13.7 | 6.30 | 4.60 | 3.70 |
| F24 | M_b | [Nm] | 18 | | | | | 18 | | | | | 18 | | | | |
| | Δm_M | [kg] | 2.2 | | | | | 2.2 | | | | | 2.2 | | | | |
| | ΔJ | [Kg ^m ·10 ⁻⁴] | 1.7 | | | | | 1.7 | | | | | 1.7 | | | | |
| F1 | Δm_M | [kg] | 3.5 | | | | | 3.5 | | | | | 3.5 | | | | |
| | ΔJ | [Kg ^m ·10 ⁻⁴] | 16 | | | | | 16 | | | | | 16 | | | | |

BMD 118 • Dimensions

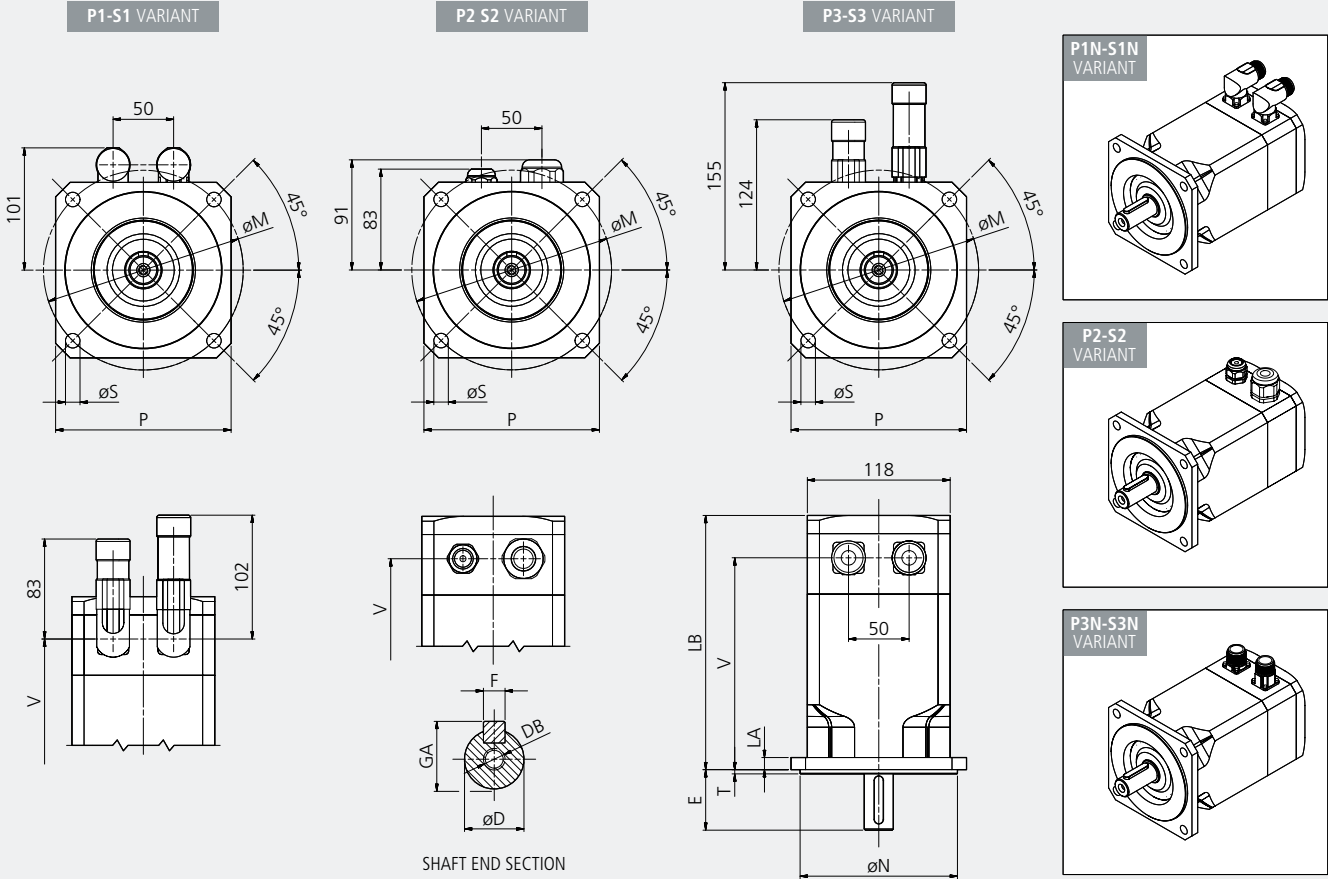

| B5 FLANGE VARIANT | | | | | | |
|-------------------|-----|-----|-----|------|-----|----|
| Flange variant | P | M | N | S | T | LA |
| 130S | 118 | 130 | 95 | 9 | 3.5 | 10 |
| 130 | 118 | 130 | 110 | 9 | 3.5 | 10 |
| 165 | 145 | 165 | 130 | 11.5 | 3.5 | 10 |

| SHAFT DIAMETER VARIANT | | | | | |
|------------------------|----|----|-----|-------------------|------------------|
| Shaft diameter | D | E | DB | GA ⁽¹⁾ | F ⁽¹⁾ |
| 19 | 19 | 40 | M6 | 21.5 | 6 |
| 24 | 24 | 50 | M8 | 27 | 8 |
| 28 | 28 | 60 | M10 | 31 | 8 |

MOTOR LENGTH DEPENDING ON THE OPTION

| DIMENSION V | | | | | | |
|----------------------|---------------------------|-----------------------|-------------------------|---------------------------------------|-----------------------|-------------------------|
| Torque | Without Brake or Flywheel | | | With Brake or Flywheel F24/F1 options | | |
| | Feedback Variants | | | Feedback Variants | | |
| M₀ | RES1/RES2/SEN | ENB1/ENB2/ENB7 | ENB3...ENB6/ENB8 | RES1/RES2/SEN | ENB1/ENB2/ENB7 | ENB3...ENB6/ENB8 |
| 5.6 | 144 | 144 | 144 | 194 | 194 | 194 |
| 10.2 | 175 | 175 | 175 | 225 | 225 | 225 |
| 14 | 208 | 208 | 208 | 258 | 258 | 258 |

| DIMENSION LB | | | | | | |
|----------------------|---------------------------|-----------------------|-------------------------|---------------------------------------|-----------------------|-------------------------|
| Torque | Without Brake or Flywheel | | | With Brake or Flywheel F24/F1 options | | |
| | Feedback Variants | | | Feedback Variants | | |
| M₀ | RES1/RES2/SEN | ENB1/ENB2/ENB7 | ENB3...ENB6/ENB8 | RES1/RES2/SEN | ENB1/ENB2/ENB7 | ENB3...ENB6/ENB8 |
| 5.6 | 179 | 204 | 179 | 229 | 254 | 229 |
| 10.2 | 210 | 235 | 210 | 260 | 258 | 260 |
| 14 | 243 | 268 | 243 | 293 | 318 | 293 |

Notes:
 (1) Motor shaft extension without key available.

BMD 145 • Ratings

| | | BMD 145 16.8 Nm | | | | | BMD145 22 Nm | | | | | |
|---------|----------------|---------------------------------------|------|------|------|------|--------------|------|------|------|------|---|
| | M_0 | [Nm] | 16.8 | | | | | 22.0 | | | | |
| | M_n | [Nm] | 16.5 | 16.0 | 14.0 | 13.0 | 12.5 | 20.7 | 19.2 | 17.0 | 15.0 | - |
| | n | [min ⁻¹] | 1600 | 3000 | 4500 | 5500 | 6000 | 1600 | 3000 | 4500 | 5500 | - |
| | f_n | [Hz] | 107 | 200 | 300 | 367 | 400 | 107 | 200 | 300 | 367 | - |
| | P_n | [kW] | 2.76 | 5.00 | 6.60 | 7.50 | 7.90 | 3.50 | 6.00 | 8.00 | 8.60 | - |
| | M_{max} | [Nm] | 46.0 | | | | | 59.0 | | | | |
| | $2p$ | [-] | 8 | | | | | 8 | | | | |
| | J | [Kgm ² ·10 ⁻⁴] | 12.8 | | | | | 17.6 | | | | |
| | τ_{el} | [ms] | 16 | | | | | 16 | | | | |
| | τ_{therm} | [min] | 36 | | | | | 47 | | | | |
| | m_M | [kg] | 15.2 | | | | | 18.2 | | | | |
| 230 Vac | V_n | [V _{AC}] | 180 | 176 | - | - | - | 185 | 202 | - | - | - |
| | I_0 | [A] | 12.1 | 22.8 | - | - | - | 15.4 | 26.5 | - | - | - |
| | I_n | [A] | 11.9 | 21.9 | - | - | - | 14.5 | 22.9 | - | - | - |
| | I_{max} | [A] | 46.0 | 88.0 | - | - | - | 51.0 | 87.0 | - | - | - |
| | K_e | [mV/min ⁻¹] | 89 | 47 | - | - | - | 102 | 60 | - | - | - |
| | K_T | [Nm/A] | 1.39 | 0.74 | - | - | - | 1.42 | 0.83 | - | - | - |
| | R_{pp} | [Ω] | 0.84 | 0.24 | - | - | - | 0.67 | 0.23 | - | - | - |
| | L_{pp} | [mH] | 13.3 | 3.80 | - | - | - | 10.6 | 3.60 | - | - | - |
| 400 Vac | V_n | [V _{AC}] | 314 | 308 | 314 | 319 | 305 | 319 | 321 | 323 | 357 | - |
| | I_0 | [A] | 6.90 | 13.0 | 19.0 | 22.8 | 26.0 | 9.00 | 16.4 | 24.3 | 26.5 | - |
| | I_n | [A] | 6.80 | 12.5 | 16.4 | 17.5 | 19.0 | 8.40 | 14.2 | 18.3 | 17.6 | - |
| | I_{max} | [A] | 26.7 | 50.0 | 73.0 | 88.0 | 100 | 29.5 | 54.0 | 80.0 | 87.0 | - |
| | K_e | [mV/min ⁻¹] | 156 | 83 | 57 | 47 | 42 | 176 | 96 | 65 | 59 | - |
| | K_T | [Nm/A] | 2.42 | 1.29 | 0.88 | 0.74 | 0.65 | 2.45 | 1.34 | 0.90 | 0.83 | - |
| | R_{pp} | [Ω] | 2.53 | 0.72 | 0.34 | 0.24 | 0.18 | 1.97 | 0.59 | 0.27 | 0.23 | - |
| | L_{pp} | [mH] | 40.4 | 11.5 | 5.40 | 3.80 | 2.90 | 31.5 | 9.40 | 4.30 | 3.60 | - |
| F24 | M_b | [Nm] | 18 | | | | | 18 | | | | |
| | Δm_M | [kg] | 2.6 | | | | | 2.6 | | | | |
| | ΔJ | [Kgm ² ·10 ⁻⁴] | 1.7 | | | | | 1.7 | | | | |
| F1 | Δm_M | [kg] | 5.0 | | | | | 5.0 | | | | |
| | ΔJ | [Kgm ² ·10 ⁻⁴] | 36 | | | | | 36 | | | | |

BMD 145 • Dimensions

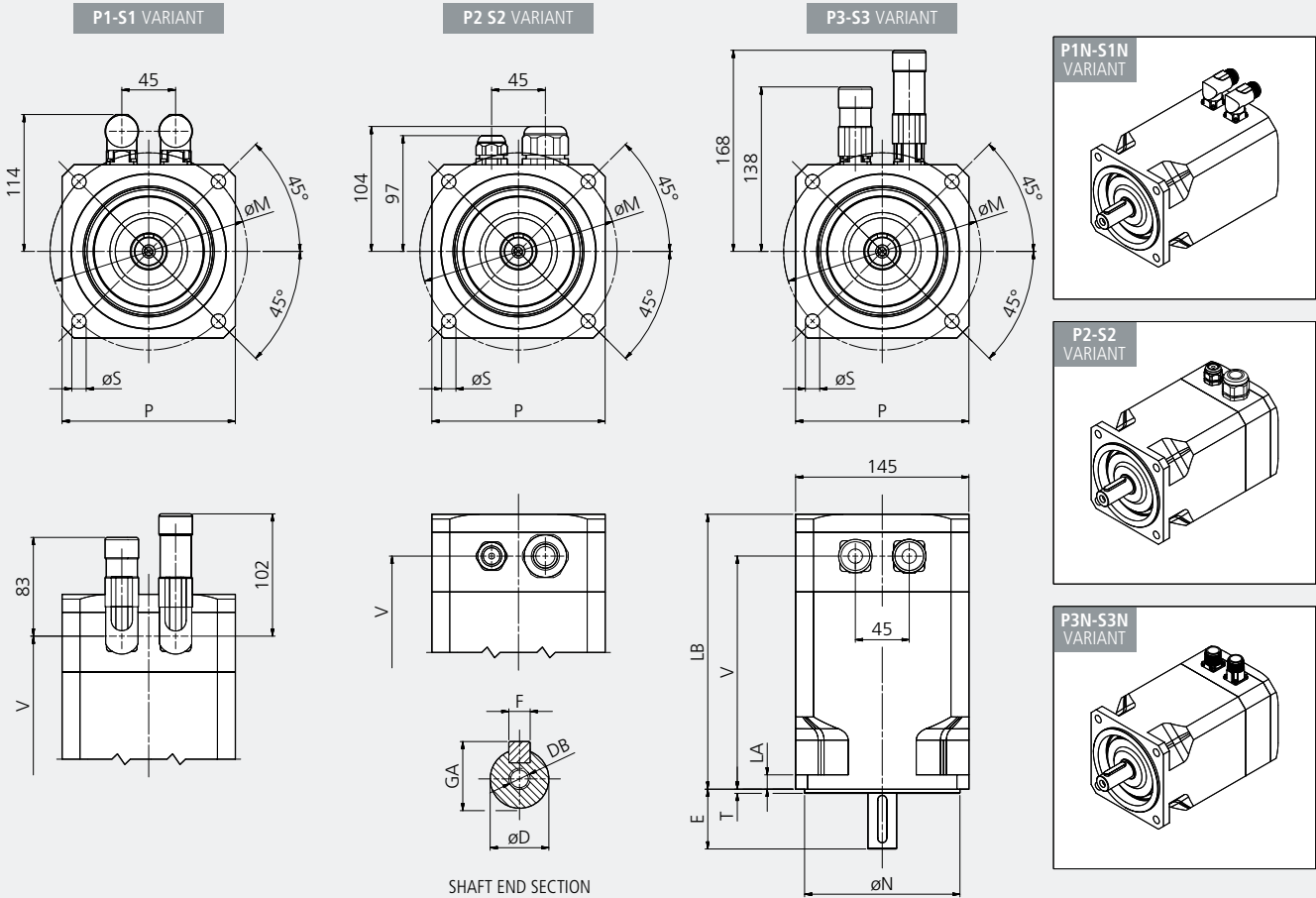

| B5 FLANGE VARIANT | | | | | | |
|-------------------|-----|-----|-----|----|-----|----|
| Flange variant | P | M | N | S | T | LA |
| 165 | 145 | 165 | 130 | 12 | 3.5 | 12 |

| SHAFT DIAMETER VARIANT | | | | | |
|------------------------|----|----|-----|-------------------|------------------|
| Shaft diameter | D | E | DB | GA ⁽¹⁾ | F ⁽¹⁾ |
| 19 | 19 | 40 | M6 | 21.5 | 6 |
| 24 | 24 | 50 | M8 | 27 | 8 |
| 28 | 28 | 60 | M10 | 31 | 8 |

MOTOR LENGTH DEPENDING ON THE OPTION

| DIMENSION V | | | | | | |
|----------------------|---------------------------|----------------|------------------|---------------------------------------|----------------|------------------|
| Torque | Without Brake or Flywheel | | | With Brake or Flywheel F24/F1 options | | |
| | Feedback Variants | | | Feedback Variants | | |
| M₀ | RES1/RES2/SEN | ENB1/ENB2/ENB7 | ENB3...ENB6/ENB8 | RES1/RES2/SEN | ENB1/ENB2/ENB7 | ENB3...ENB6/ENB8 |
| 16.8 | 195 | 195 | 195 | 245 | 245 | 245 |
| 22 | 230 | 230 | 230 | 280 | 280 | 280 |

| DIMENSION LB | | | | | | |
|----------------------|---------------------------|----------------|------------------|---------------------------------------|----------------|------------------|
| Torque | Without Brake or Flywheel | | | With Brake or Flywheel F24/F1 options | | |
| | Feedback Variants | | | Feedback Variants | | |
| M₀ | RES1/RES2/SEN | ENB1/ENB2/ENB7 | ENB3...ENB6/ENB8 | RES1/RES2/SEN | ENB1/ENB2/ENB7 | ENB3...ENB6/ENB8 |
| 16.8 | 230 | 255 | 230 | 280 | 305 | 280 |
| 22 | 265 | 290 | 265 | 315 | 375 | 315 |

Notes:
 (1) Motor shaft extension without key available.

BMD 145 with Forced Ventilation option • Ratings

| | | BMD 145 16.8 Nm with Forced Ventilation | | | | | BMD145 22 Nm with Forced Ventilation | | | | | |
|----------------|---------------------------------------|---|------|------|------|------|--------------------------------------|------|------|------|---|---|
| M_0 | [Nm] | 21.5 | | | | | 27.5 | | | | | |
| M_n | [Nm] | 20.5 | 19.2 | 17.2 | 15.7 | - | 27.4 | 26.1 | 24.3 | - | - | |
| n | [min ⁻¹] | 1600 | 3000 | 4500 | 5500 | - | 1600 | 3000 | 4500 | - | - | |
| f_n | [Hz] | 107 | 200 | 300 | 367 | - | 107 | 200 | 300 | - | - | |
| P_n | [kW] | 3.43 | 6.00 | 8.10 | 9.00 | - | 4.60 | 8.20 | 11.5 | - | - | |
| M_{max} | [Nm] | 46.0 | | | | | 59.0 | | | | | |
| $2p$ | [-] | 8 | | | | | 8 | | | | | |
| J | [Kgm ² ·10 ⁻⁴] | 12.8 | | | | | 17.6 | | | | | |
| τ_{el} | [ms] | 16 | | | | | 16 | | | | | |
| τ_{therm} | [min] | 17 | | | | | 22 | | | | | |
| m_M | [kg] | 18.7 | | | | | 21.7 | | | | | |
| 230 Vac | V_n | [V _{AC}] | 203 | 195 | - | - | - | 214 | - | - | - | - |
| | I_0 | [A] | 16.3 | 30.0 | - | - | - | 19.8 | - | - | - | - |
| | I_n | [A] | 15.5 | 26.6 | - | - | - | 19.6 | - | - | - | - |
| | I_{max} | [A] | 46.0 | 88.0 | - | - | - | 51.0 | - | - | - | - |
| | K_e | [mV/min ⁻¹] | 89 | 47 | - | - | - | 102 | - | - | - | - |
| | K_T | [Nm/A] | 1.32 | 0.72 | - | - | - | 1.39 | - | - | - | - |
| | R_{pp} | [Ω] | 0.84 | 0.24 | - | - | - | 0.67 | - | - | - | - |
| | L_{pp} | [mH] | 13.3 | 3.80 | - | - | - | 10.6 | - | - | - | - |
| 400 Vac | V_n | [V _{AC}] | 345 | 331 | 322 | 323 | - | 363 | 352 | 348 | - | - |
| | I_0 | [A] | 9.45 | 17.6 | 25.8 | 30.0 | - | 11.5 | 21.1 | 30.0 | - | - |
| | I_n | [A] | 8.90 | 15.2 | 20.0 | 21.6 | - | 11.4 | 19.8 | 27.1 | - | - |
| | I_{max} | [A] | 26.7 | 50.0 | 73.0 | 88.0 | - | 29.5 | 54.0 | 80.0 | - | - |
| | K_e | [mV/min ⁻¹] | 156 | 83 | 57 | 47 | - | 176 | 96 | 65 | - | - |
| | K_T | [Nm/A] | 2.28 | 1.23 | 0.83 | 0.72 | - | 2.39 | 1.31 | 0.92 | - | - |
| | R_{pp} | [Ω] | 2.53 | 0.72 | 0.34 | 0.24 | - | 1.97 | 0.59 | 0.27 | - | - |
| | L_{pp} | [mH] | 40.4 | 11.5 | 5.40 | 3.80 | - | 31.5 | 9.40 | 4.30 | - | - |
| F24 | M_b | [Nm] | 18 | | | | | 18 | | | | |
| | Δm_M | [kg] | 2.6 | | | | | 2.6 | | | | |
| | ΔJ | [Kgm ² ·10 ⁻⁴] | 1.7 | | | | | 1.7 | | | | |
| F1 | Δm_M | [kg] | 5.0 | | | | | 5.0 | | | | |
| | ΔJ | [Kgm ² ·10 ⁻⁴] | 36 | | | | | 36 | | | | |

BMD 145 with Forced Ventilation option • Dimensions

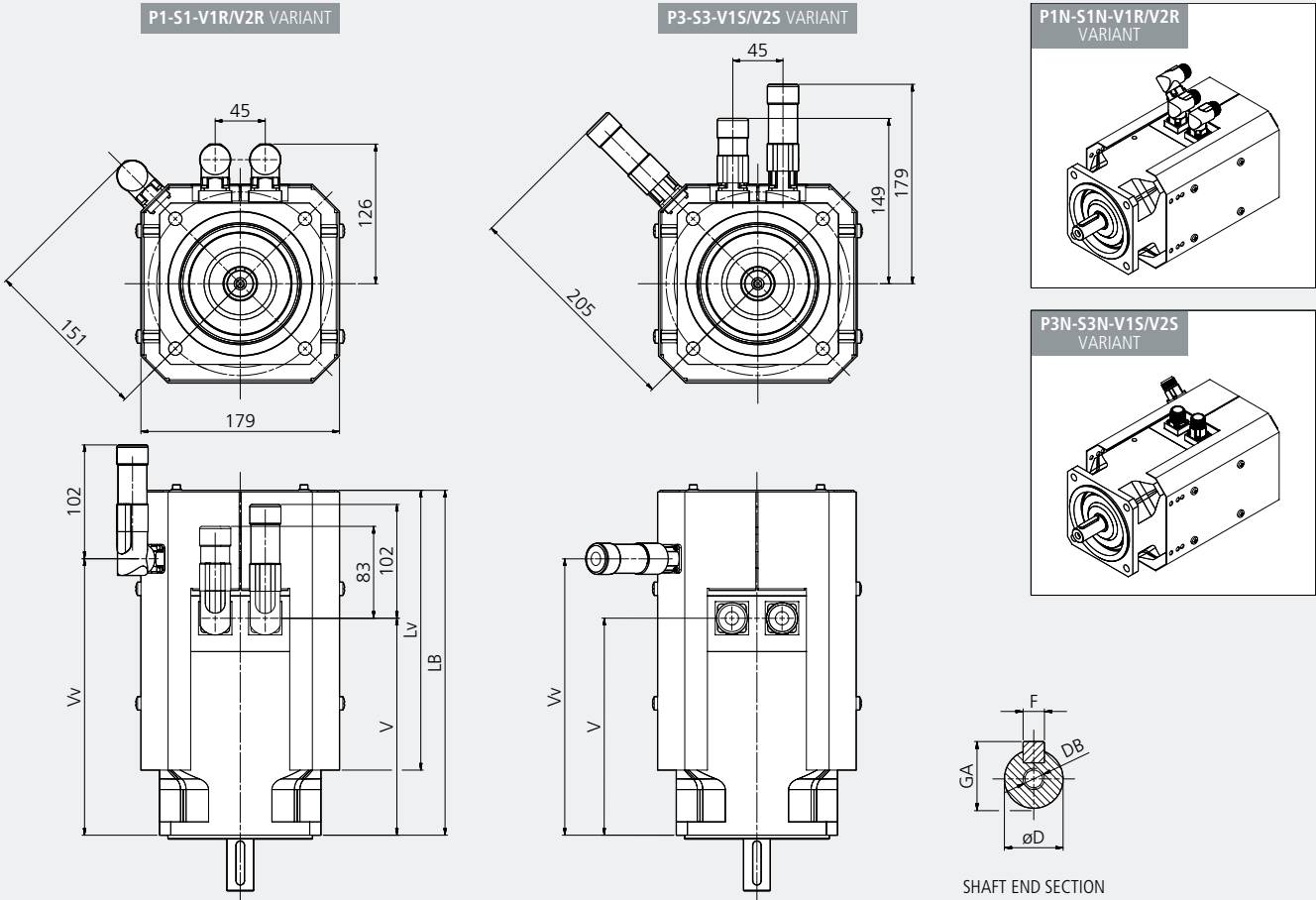

| B5 FLANGE VARIANT | | | | | | |
|-------------------|-----|-----|-----|----|-----|----|
| Flange variant | P | M | N | S | T | LA |
| 165 | 145 | 165 | 130 | 12 | 3.5 | 12 |

| SHAFT DIAMETER VARIANT | | | | | |
|------------------------|----|----|-----|-------------------|------------------|
| Shaft diameter | D | E | DB | GA ⁽¹⁾ | F ⁽¹⁾ |
| 19 | 19 | 40 | M6 | 21.5 | 6 |
| 24 | 24 | 50 | M8 | 27 | 8 |
| 28 | 28 | 60 | M10 | 31 | 8 |

MOTOR LENGTH DEPENDING ON THE OPTION

DIMENSION V - (Vv)

| Torque | Without Brake or Flywheel | | | With Brake or Flywheel F24/F1 options | | |
|----------------------|---------------------------|-----------------------|-------------------------|---------------------------------------|-----------------------|-------------------------|
| | Feedback Variants | | | Feedback Variants | | |
| M₀ | RES1/RES2/SEN | ENB1/ENB2/ENB7 | ENB3...ENB6/ENB8 | RES1/RES2/SEN | ENB1/ENB2/ENB7 | ENB3...ENB6/ENB8 |
| 16.8 | 195 - (249) | 195 - (274) | 195 - (249) | 245 - (299) | 245 - (324) | 245 - (299) |
| 22 | 230 - (284) | 230 - (309) | 230 - (284) | 280 - (334) | 280 - (394) | 280 - (334) |

DIMENSION LB - (Lv)

| Torque | Without Brake or Flywheel | | | With Brake or Flywheel F24/F1 options | | |
|----------------------|---------------------------|-----------------------|-------------------------|---------------------------------------|-----------------------|-------------------------|
| | Feedback Variants | | | Feedback Variants | | |
| M₀ | RES1/RES2/SEN | ENB1/ENB2/ENB7 | ENB3...ENB6/ENB8 | RES1/RES2/SEN | ENB1/ENB2/ENB7 | ENB3...ENB6/ENB8 |
| 16.8 | 310 - (252) | 335 - (252) | 310 - (252) | 360 - (252) | 385 - (312) | 360 - (252) |
| 22 | 345 - (252) | 370 - (312) | 345 - (252) | 395 - (312) | 455 - (312) | 395 - (312) |

Notes:
(1) Motor shaft extension without key available.

BMD 170 • Ratings

| | | BMD 170 34 Nm | | | | | BMD170 45 Nm | | | | | |
|---------|----------------|--|------|------|---|---|--------------|------|------|---|---|---|
| | M_0 | [Nm] | 34.0 | | | | | 45.0 | | | | |
| | M_n | [Nm] | 31.0 | 27.5 | - | - | - | 42.0 | 36.0 | - | - | - |
| | n | [min ⁻¹] | 1600 | 3000 | - | - | - | 1600 | 3000 | - | - | - |
| | f_n | [Hz] | 107 | 200 | - | - | - | 107 | 200 | - | - | - |
| | P_n | [kW] | 5.20 | 8.60 | - | - | - | 7.00 | 11.3 | - | - | - |
| | M_{max} | [Nm] | 90.0 | | | | | 125 | | | | |
| | $2p$ | [-] | 8 | | | | | 8 | | | | |
| | J | [Kgm ² · 10 ⁻⁴] | 33.8 | | | | | 47.5 | | | | |
| | τ_{el} | [ms] | 20 | | | | | 19 | | | | |
| | τ_{therm} | [min] | 50 | | | | | 65 | | | | |
| | m_M | [kg] | 25 | | | | | 30 | | | | |
| 230 Vac | V_n | [V _{AC}] | 181 | 182 | - | - | - | - | - | - | - | - |
| | I_0 | [A] | 21.8 | 40.4 | - | - | - | - | - | - | - | - |
| | I_n | [A] | 19.7 | 32.2 | - | - | - | - | - | - | - | - |
| | I_{max} | [A] | 66.0 | 121 | - | - | - | - | - | - | - | - |
| | K_e | [mV/min ⁻¹] | 99 | 54 | - | - | - | - | - | - | - | - |
| | K_T | [Nm/A] | 1.56 | 0.84 | - | - | - | - | - | - | - | - |
| | R_{pp} | [Ω] | 0.30 | 0.09 | - | - | - | - | - | - | - | - |
| | L_{pp} | [mH] | 5.80 | 1.70 | - | - | - | - | - | - | - | - |
| 400 Vac | V_n | [V _{AC}] | 319 | 315 | - | - | - | 310 | 314 | - | - | - |
| | I_0 | [A] | 12.4 | 23.3 | - | - | - | 17.1 | 31.0 | - | - | - |
| | I_n | [A] | 11.2 | 18.6 | - | - | - | 15.9 | 24.9 | - | - | - |
| | I_{max} | [A] | 37.0 | 70.0 | - | - | - | 52.0 | 96.0 | - | - | - |
| | K_e | [mV/min ⁻¹] | 174 | 93 | - | - | - | 185 | 101 | - | - | - |
| | K_T | [Nm/A] | 2.74 | 1.46 | - | - | - | 2.64 | 1.50 | - | - | - |
| | R_{pp} | [Ω] | 0.91 | 0.26 | - | - | - | 0.57 | 0.17 | - | - | - |
| | L_{pp} | [mH] | 17.9 | 5.10 | - | - | - | 11.1 | 3.30 | - | - | - |
| F24 | M_b | [Nm] | 36 | | | | | 36 | | | | |
| | Δm_M | [kg] | 4.5 | | | | | 4.5 | | | | |
| | ΔJ | [Kgm ² · 10 ⁻⁴] | 5.6 | | | | | 5.6 | | | | |
| F1 | Δm_M | [kg] | 8.2 | | | | | 8.2 | | | | |
| | ΔJ | [Kgm ² · 10 ⁻⁴] | 70 | | | | | 70 | | | | |

BMD 170 • Dimensions

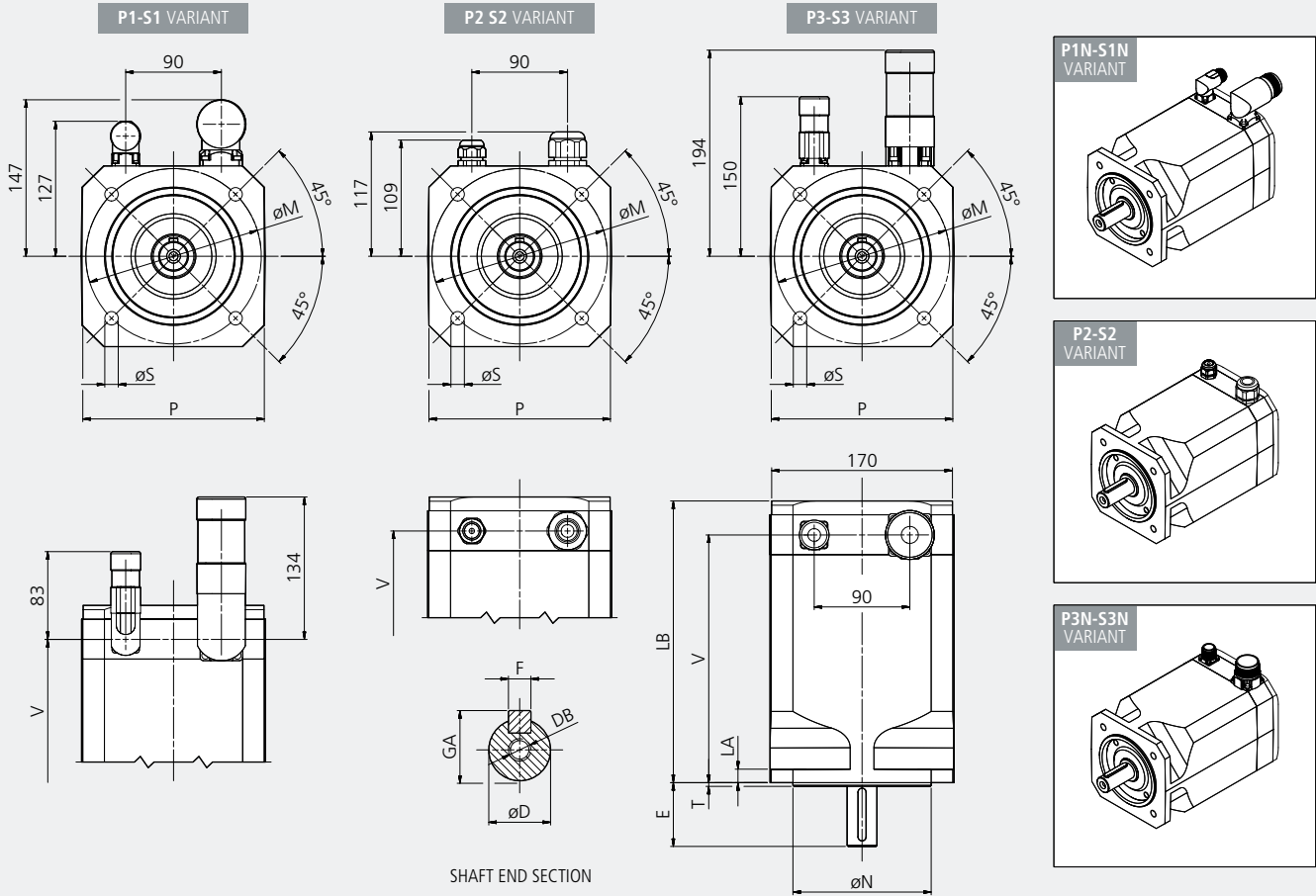

| B5 FLANGE VARIANT | | | | | | |
|-------------------|-----|-----|-----|----|-----|----|
| Flange variant | P | M | N | S | T | LA |
| 165 | 170 | 165 | 130 | 12 | 3.5 | 12 |

| SHAFT DIAMETER VARIANT | | | | | |
|------------------------|----|----|-----|-------------------|------------------|
| Shaft diameter | D | E | DB | GA ⁽¹⁾ | F ⁽¹⁾ |
| 24 | 24 | 50 | M8 | 27 | 8 |
| 28 | 28 | 60 | M10 | 31 | 8 |
| 32 | 32 | 60 | M12 | 35 | 10 |

MOTOR LENGTH DEPENDING ON THE OPTION

| DIMENSION V | | | | | | |
|----------------------|---------------------------|-----------------------|-------------------------|---------------------------------------|-----------------------|-------------------------|
| Torque | Without Brake or Flywheel | | | With Brake or Flywheel F24/F1 options | | |
| | Feedback Variants | | | Feedback Variants | | |
| M₀ | RES1/RES2/SEN | ENB1/ENB2/ENB7 | ENB3...ENB6/ENB8 | RES1/RES2/SEN | ENB1/ENB2/ENB7 | ENB3...ENB6/ENB8 |
| 34 | 233 | 233 | 233 | 308 | 308 | 308 |
| 45 | 287 | 287 | 287 | 362 | 362 | 362 |

| DIMENSION LB | | | | | | |
|----------------------|---------------------------|-----------------------|-------------------------|---------------------------------------|-----------------------|-------------------------|
| Torque | Without Brake or Flywheel | | | With Brake or Flywheel F24/F1 options | | |
| | Feedback Variants | | | Feedback Variants | | |
| M₀ | RES1/RES2/SEN | ENB1/ENB2/ENB7 | ENB3...ENB6/ENB8 | RES1/RES2/SEN | ENB1/ENB2/ENB7 | ENB3...ENB6/ENB8 |
| 34 | 265 | 303 | 265 | 340 | 378 | 340 |
| 45 | 319 | 357 | 319 | 394 | 432 | 394 |

Notes:
 (1) Motor shaft extension without key available.

BMD 170 with Forced Ventilation option • Ratings

| | | | BMD 170 34 Nm with Forced Ventilation | | | | | BMD170 45 Nm with Forced Ventilation | | | | |
|---------|----------------|---------------------------------------|---------------------------------------|------|---|---|---|--------------------------------------|------|---|---|---|
| | M_0 | [Nm] | 44.0 | | | | | 60.0 | | | | |
| | M_n | [Nm] | 42.0 | 39.0 | - | - | - | 57.0 | 53.0 | - | - | - |
| | n | [min ⁻¹] | 1600 | 3000 | - | - | - | 1600 | 3000 | - | - | - |
| | f_n | [Hz] | 107 | 200 | - | - | - | 107 | 200 | - | - | - |
| | P_n | [kW] | 7.00 | 12.2 | - | - | - | 9.50 | 16.6 | - | - | - |
| | M_{max} | [Nm] | 90.0 | | | | | 125 | | | | |
| | $2p$ | [-] | 8 | | | | | 8 | | | | |
| | J | [Kgm ² ·10 ⁻⁴] | 33.8 | | | | | 47.5 | | | | |
| | τ_{el} | [ms] | 20 | | | | | 19 | | | | |
| | τ_{therm} | [min] | 23 | | | | | 29 | | | | |
| | m_M | [kg] | 29 | | | | | 34 | | | | |
| 230 Vac | V_n | [V _{AC}] | 207 | 205 | - | - | - | - | - | - | - | - |
| | I_0 | [A] | 29.8 | 55.1 | - | - | - | - | - | - | - | - |
| | I_n | [A] | 28.7 | 48.9 | - | - | - | - | - | - | - | - |
| | I_{max} | [A] | 66.0 | 121 | - | - | - | - | - | - | - | - |
| | K_e | [mV/min ⁻¹] | 99 | 54 | - | - | - | - | - | - | - | - |
| | K_T | [Nm/A] | 1.48 | 0.80 | - | - | - | - | - | - | - | - |
| | R_{pp} | [Ω] | 0.3 | 0.09 | - | - | - | - | - | - | - | - |
| | L_{pp} | [mH] | 5.8 | 1.7 | - | - | - | - | - | - | - | - |
| 400 Vac | V_n | [V _{AC}] | 350 | 342 | - | - | - | 361 | 351 | - | - | - |
| | I_0 | [A] | 17.0 | 31.8 | - | - | - | 23.0 | 42.0 | - | - | - |
| | I_n | [A] | 16.3 | 28.2 | - | - | - | 21.5 | 36.3 | - | - | - |
| | I_{max} | [A] | 37.0 | 70.0 | - | - | - | 52.0 | 96.0 | - | - | - |
| | K_e | [mV/min ⁻¹] | 174 | 93 | - | - | - | 185 | 101 | - | - | - |
| | K_T | [Nm/A] | 2.59 | 1.39 | - | - | - | 2.62 | 1.43 | - | - | - |
| | R_{pp} | [Ω] | 0.91 | 0.26 | - | - | - | 0.57 | 0.17 | - | - | - |
| | L_{pp} | [mH] | 17.9 | 5.10 | - | - | - | 11.1 | 3.30 | - | - | - |
| F24 | M_b | [Nm] | 36 | | | | | 36 | | | | |
| | Δm_M | [kg] | 4.5 | | | | | 4.5 | | | | |
| | ΔJ | [Kgm ² ·10 ⁻⁴] | 5.6 | | | | | 5.6 | | | | |
| F1 | Δm_M | [kg] | 8.2 | | | | | 8.2 | | | | |
| | ΔJ | [Kgm ² ·10 ⁻⁴] | 70 | | | | | 70 | | | | |

BMD 170 with Forced Ventilation option • Dimensions

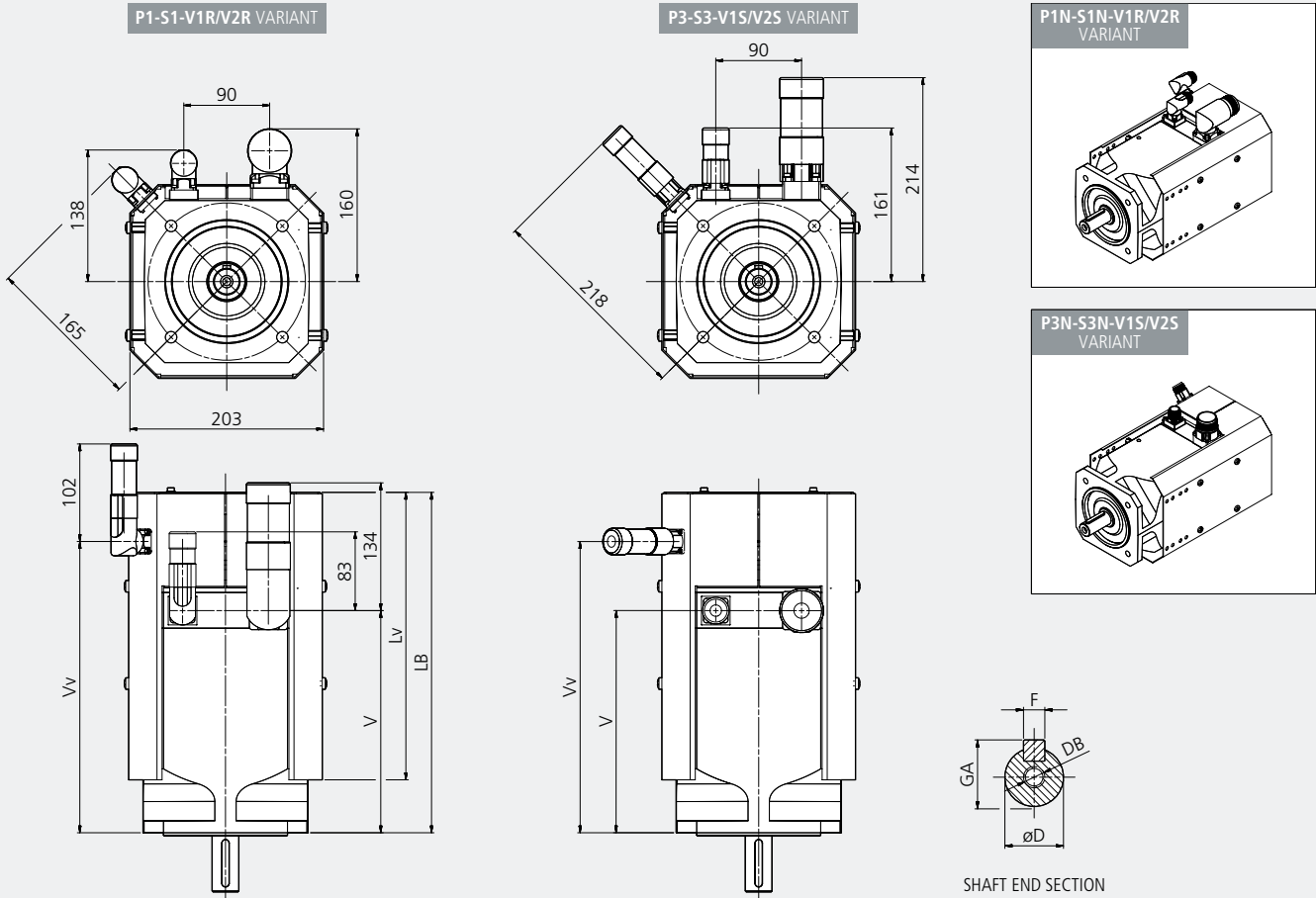

| B5 FLANGE VARIANT | | | | | | |
|-------------------|-----|-----|-----|----|-----|----|
| Flange variant | P | M | N | S | T | LA |
| 165 | 170 | 165 | 130 | 12 | 3.5 | 12 |

| SHAFT DIAMETER VARIANT | | | | | |
|------------------------|----|----|-----|-------------------|------------------|
| Shaft diameter | D | E | DB | GA ⁽¹⁾ | F ⁽¹⁾ |
| 24 | 24 | 50 | M8 | 27 | 8 |
| 28 | 28 | 60 | M10 | 31 | 8 |
| 32 | 32 | 60 | M12 | 35 | 10 |

MOTOR LENGTH DEPENDING ON THE OPTION

DIMENSION V - (Vv)

| Torque | Without Brake or Flywheel | | | With Brake or Flywheel F24/F1 options | | |
|----------------------|---------------------------|-----------------------|-------------------------|---------------------------------------|-----------------------|-------------------------|
| | Feedback Variants | | | Feedback Variants | | |
| M₀ | RES1/RES2/SEN | ENB1/ENB2/ENB7 | ENB3...ENB6/ENB8 | RES1/RES2/SEN | ENB1/ENB2/ENB7 | ENB3...ENB6/ENB8 |
| 34 | 233 - (306) | 233 - (344) | 233 - (306) | 308 - (381) | 308 - (427) | 308 - (381) |
| 45 | 287 - (360) | 287 - (398) | 287 - (360) | 362 - (435) | 362 - (473) | 362 - (435) |

DIMENSION LB - (Lv)

| Torque | Without Brake or Flywheel | | | With Brake or Flywheel F24/F1 options | | |
|----------------------|---------------------------|-----------------------|-------------------------|---------------------------------------|-----------------------|-------------------------|
| | Feedback Variants | | | Feedback Variants | | |
| M₀ | RES1/RES2/SEN | ENB1/ENB2/ENB7 | ENB3...ENB6/ENB8 | RES1/RES2/SEN | ENB1/ENB2/ENB7 | ENB3...ENB6/ENB8 |
| 34 | 357 - (302) | 395 - (302) | 357 - (302) | 432 - (302) | 478 - (377) | 432 - (302) |
| 45 | 411 - (302) | 449 - (302) | 411 - (302) | 486 - (377) | 524 - (377) | 486 - (377) |

Notes:
(1) Motor shaft extension without key available.

Torque-speed characteristic

The permissible operating range of a brushless servomotor is limited by thermal, mechanical, and electromagnetic limits.

The thermal limit is dependent on the thermal class of the insulation system (F). To adhere to the temperature limits, the torque must be reduced as the speed increases, starting from stall torque M_0 . The maximum permissible torque is then dependent on the operation mode. The characteristic curves are assigned for continuous duty S1 and intermittent periodic duty S3 with a cycle time of 10 minutes, except for small motors, for which a cycle time of 1 minute is specified and noted in the characteristic curves. A transient, high overload capacity up to M_{max} is provided.

The speed range is limited by the maximum mechanical speed and the voltage limit. The voltage limit is usually lower than the mechanical limit. The voltage limiting characteristic curve is determined by the motor nominal speed. The characteristic curves for each nominal speed are reported in the same diagram. For drive sizing convenience, it is preferable to select the motor whose voltage limit curve does not lie too far above the maximum speed required for the application.

Therefore, the performance characteristics of a brushless motor are described by a torque and speed operating area. The continuous duty zone is bordered by the maximum continuous torque curve up to the intersection with the voltage limit curve. Continuous duty in the area above the S1 characteristic curve is not thermally permitted for the motor. The intermittent periodic duty zone is bordered by the peak torque line and the voltage limit curve.

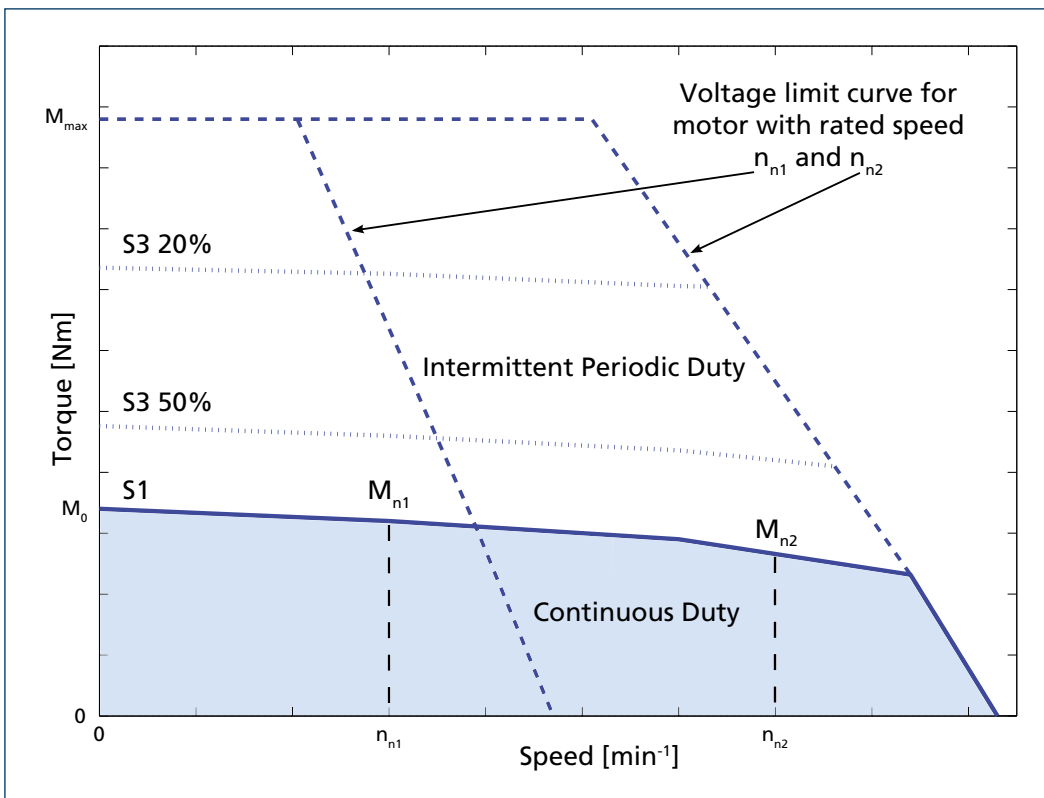

BMD 65 • Torque-speed curves

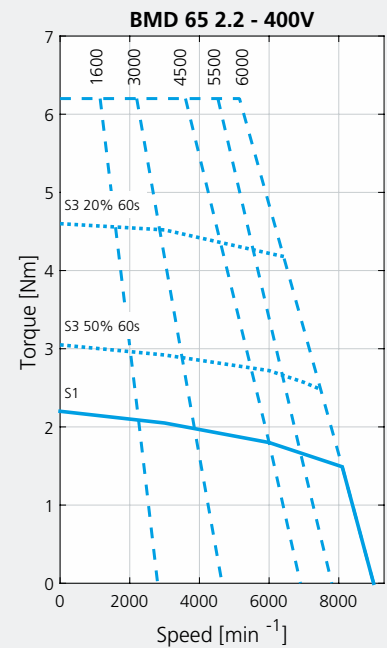
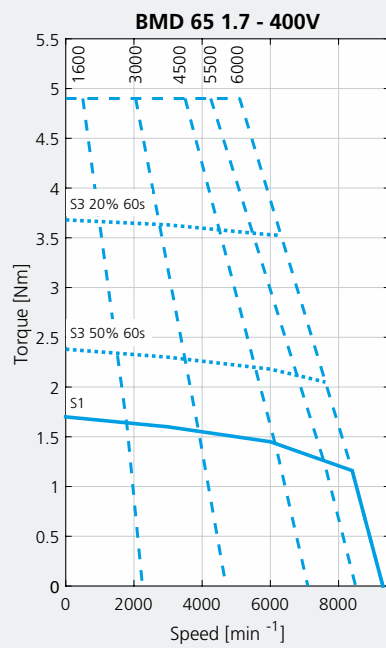
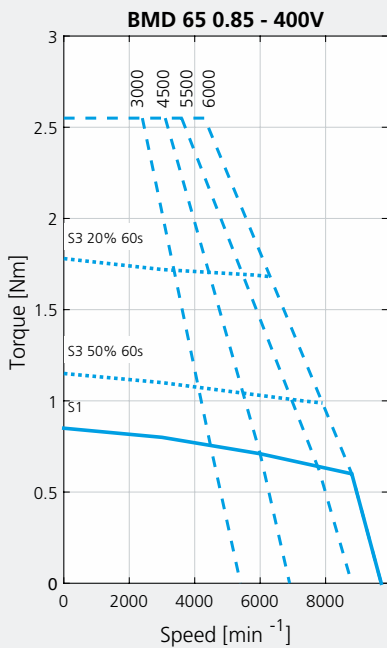
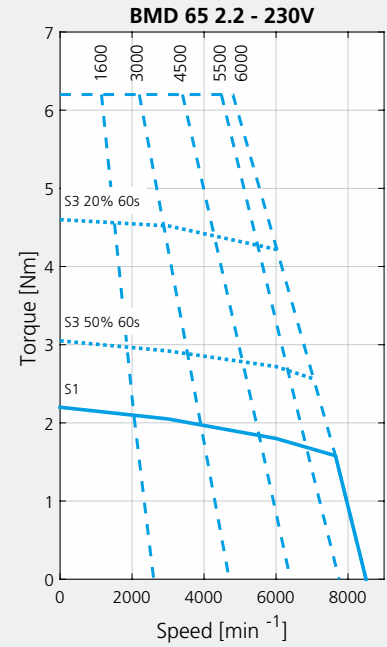
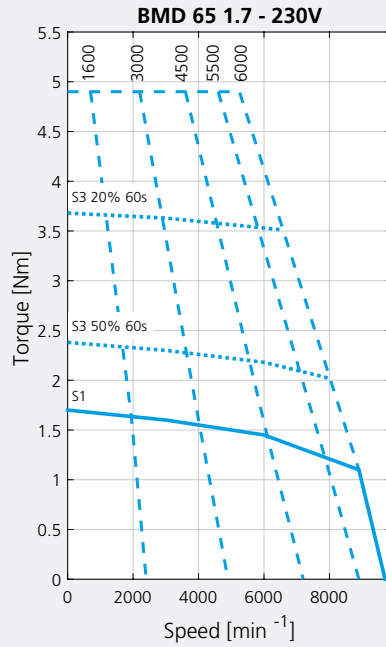
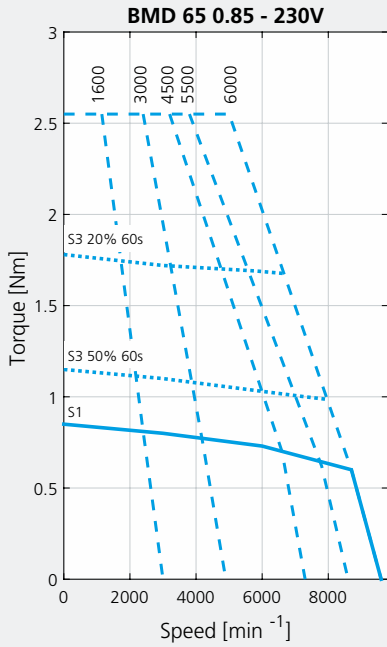

BMD 82 • Torque-speed curves

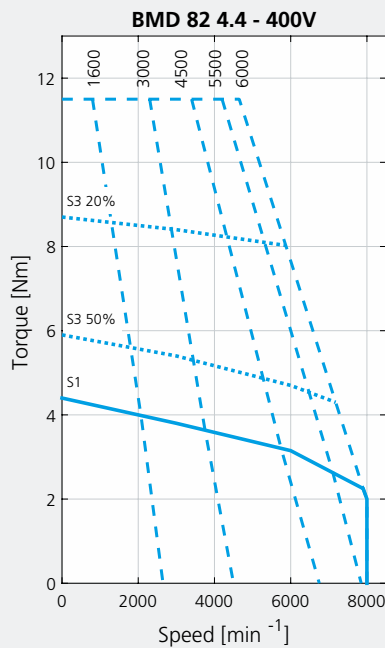
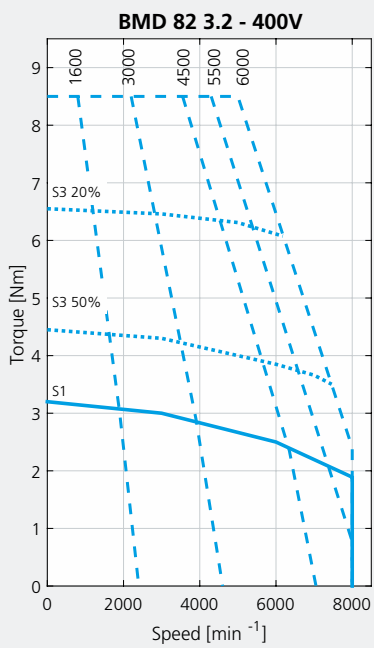
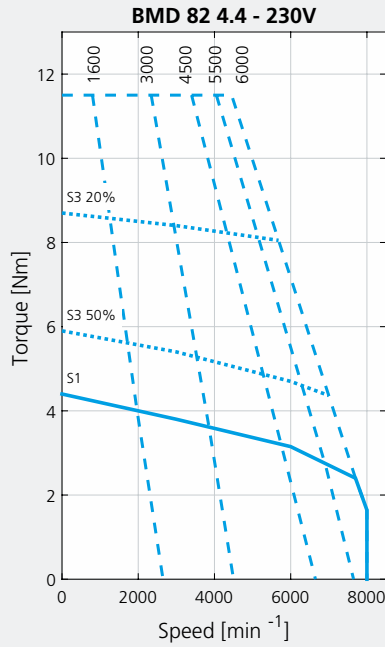
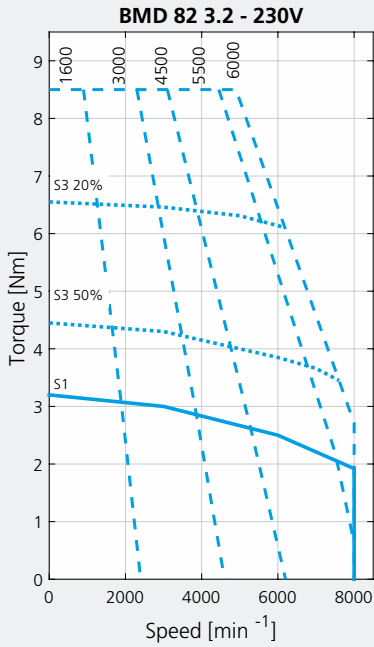

BMD 102 • Torque-speed curves

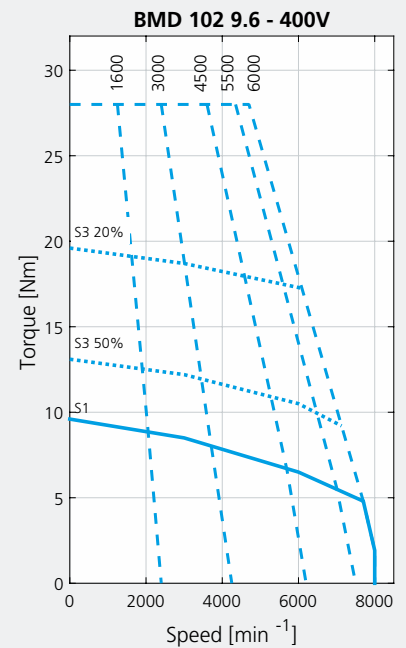
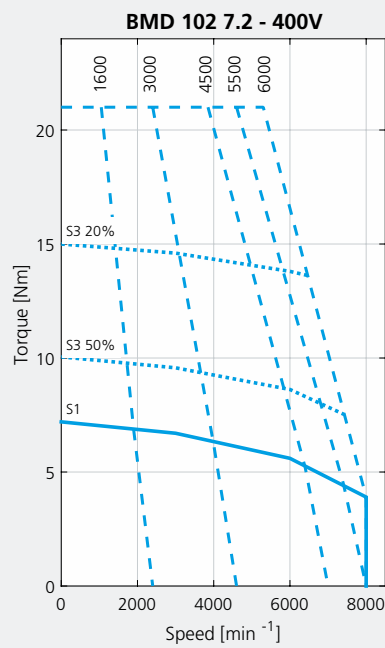
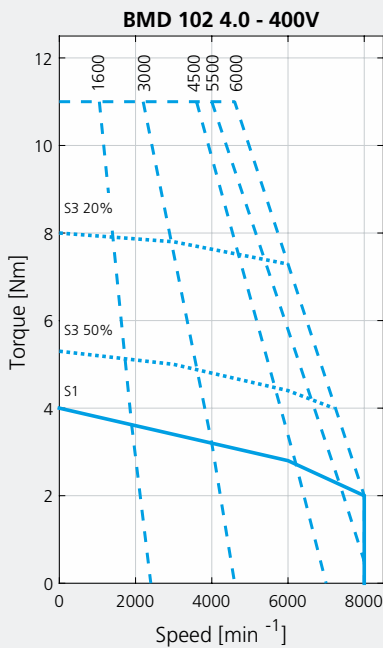
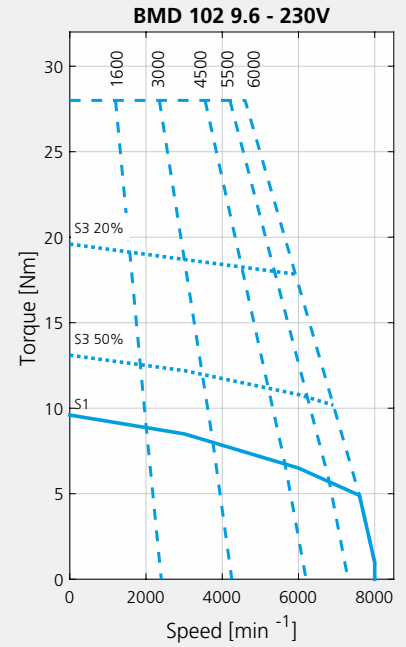
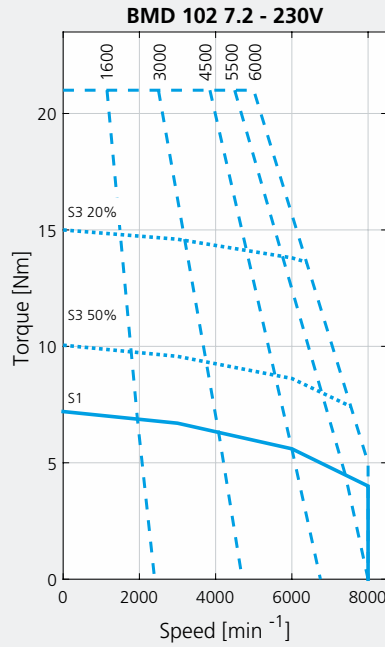
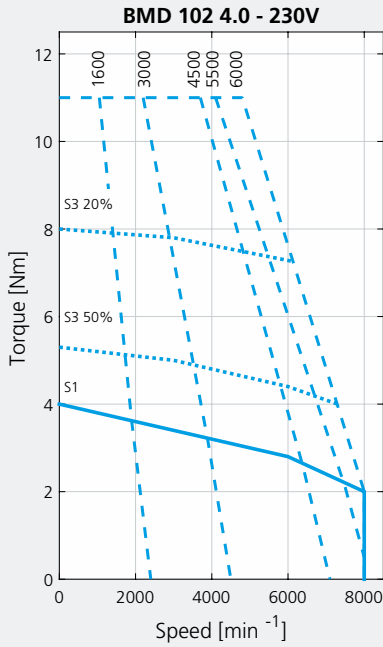

BMD 118 • Torque-speed curves

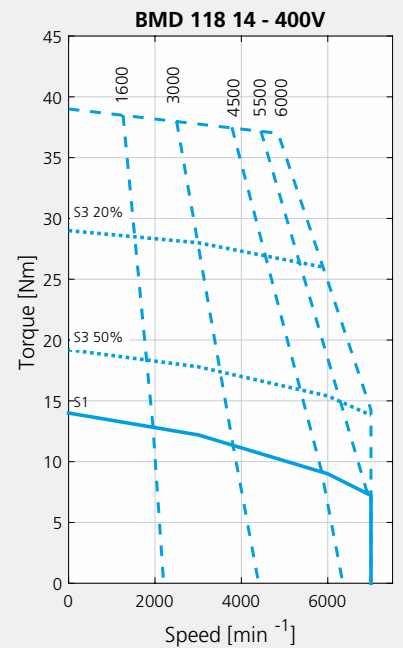
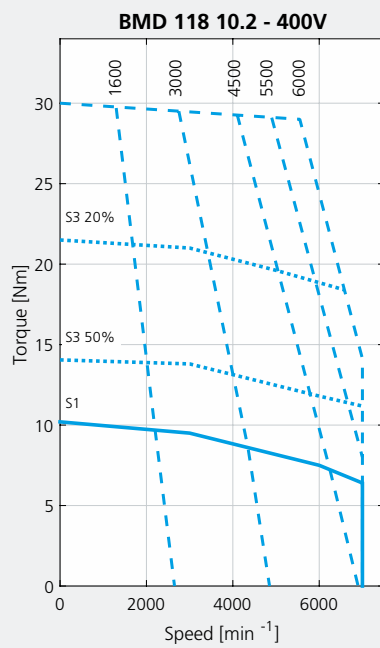
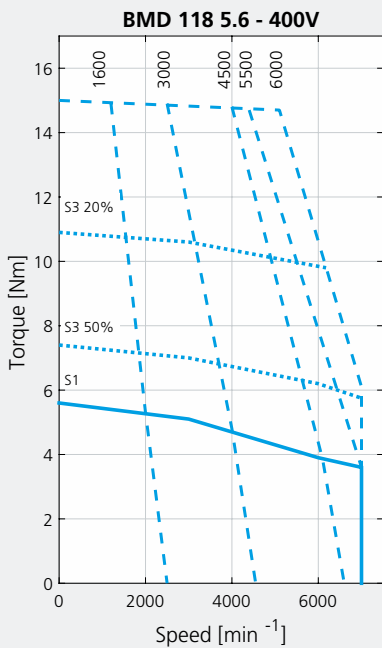
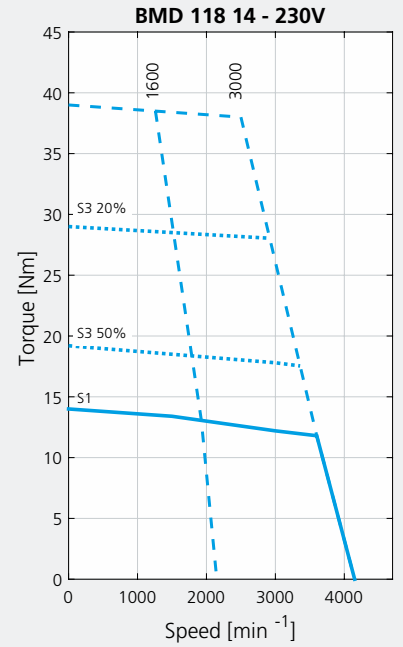
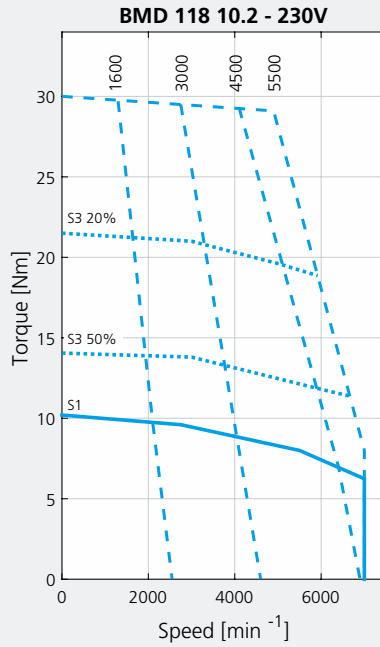
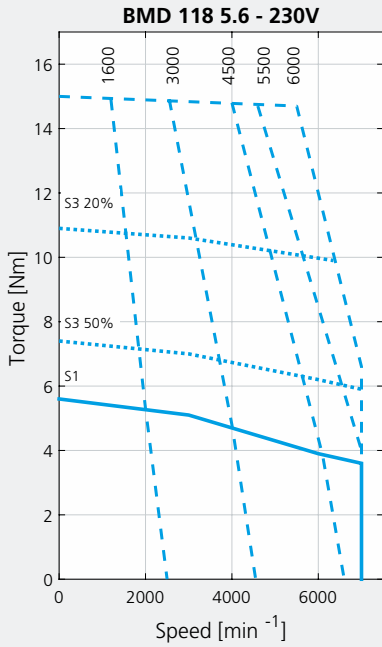

BMD 145 • Torque-speed curves

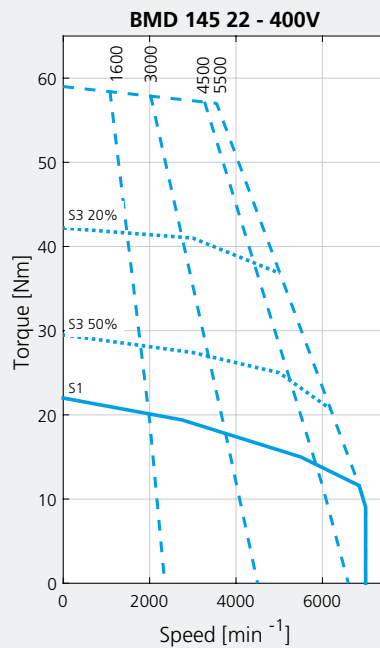
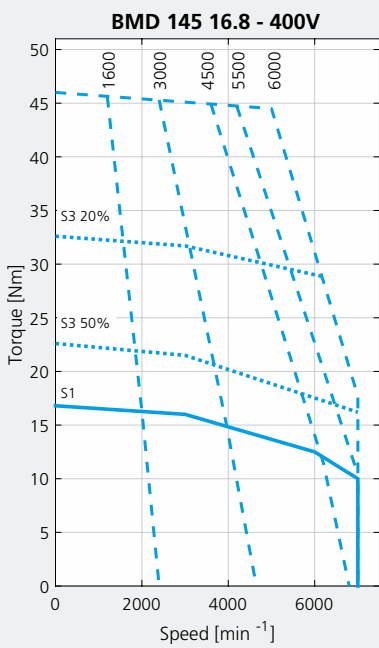
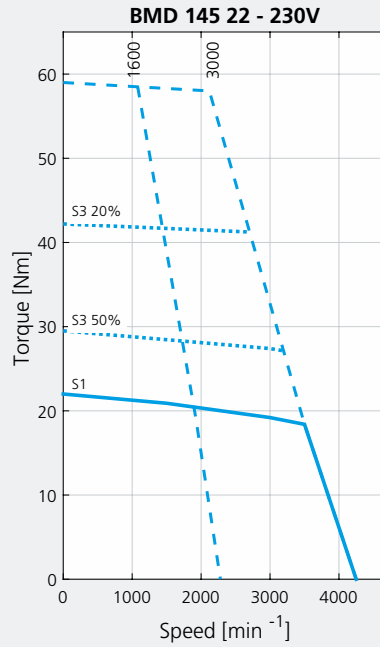
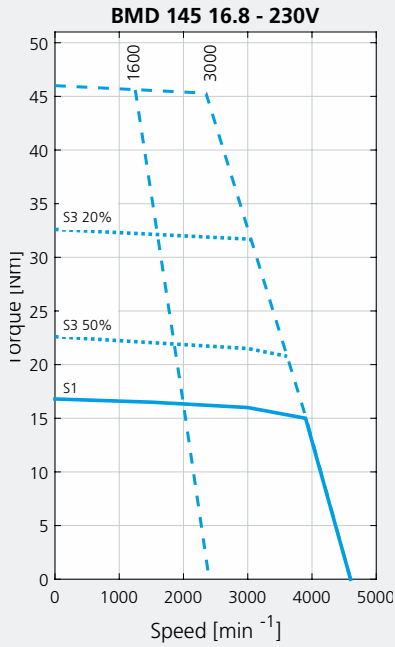

BMD 145 with Forced Ventilation option

Torque-speed curves

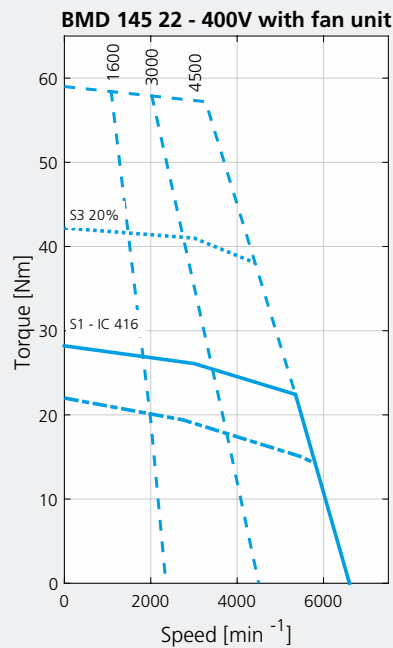
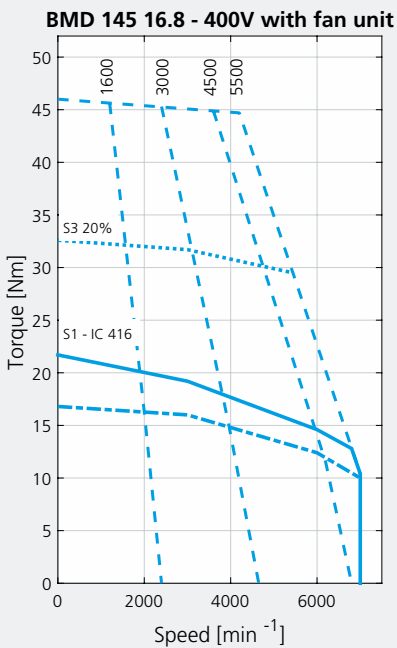
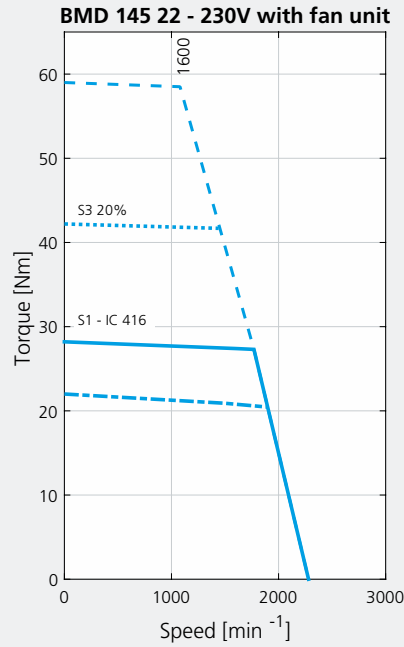
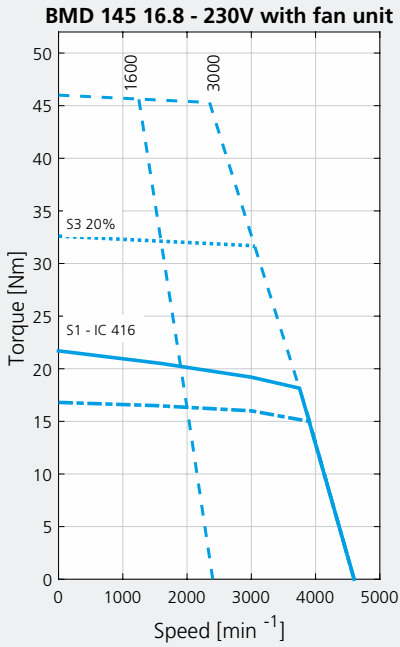

BMD 170 • Torque-speed curves

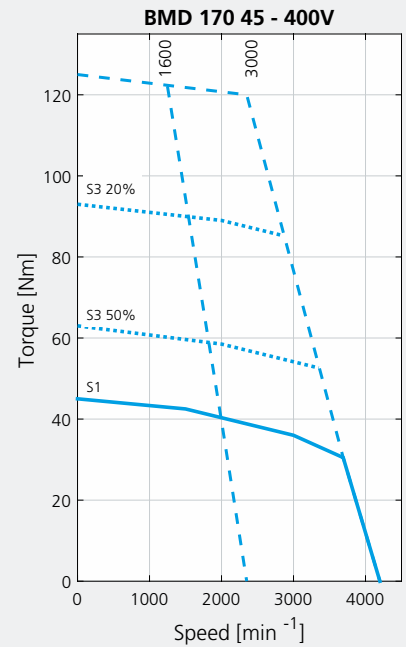
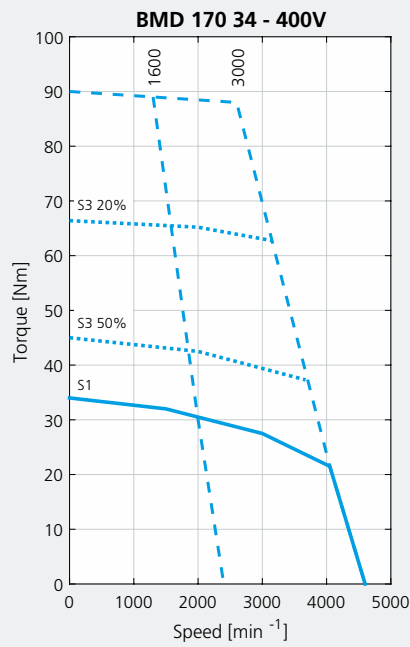
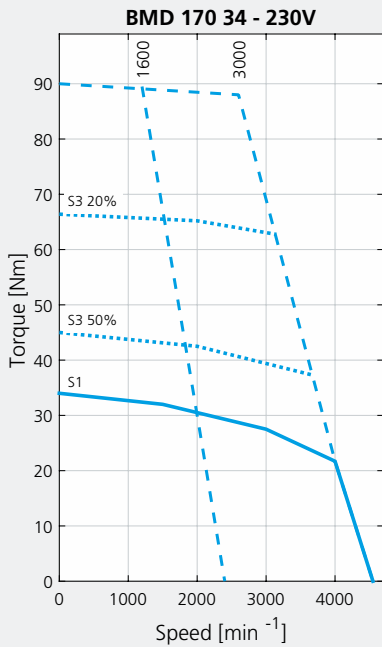

BMD 170 with Forced Ventilation option Torque-speed curves

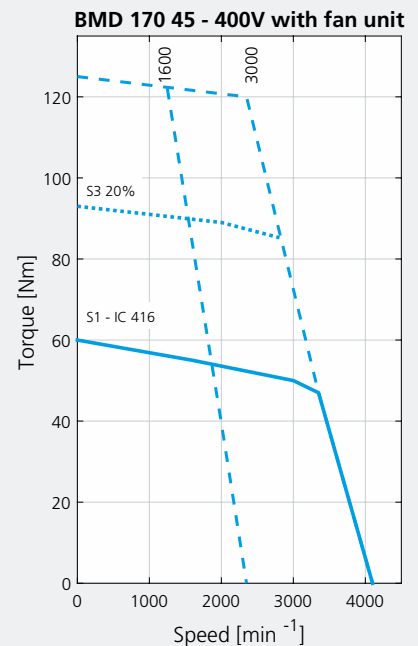
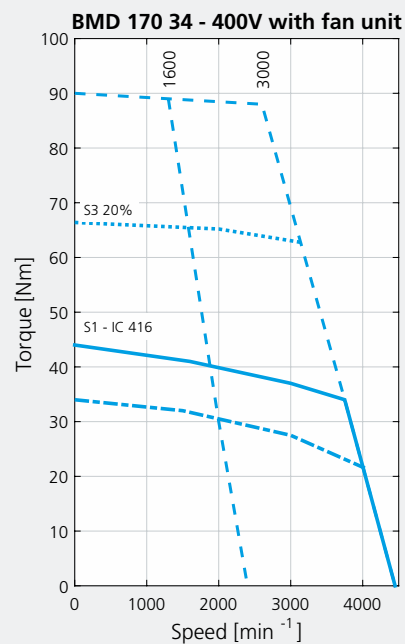
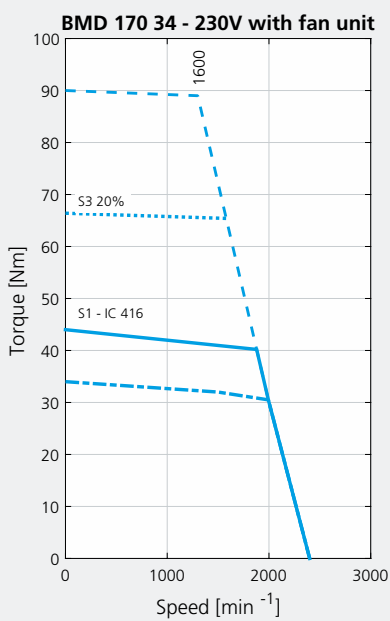

Feedback devices

SENSORLESS: [SEN]

Thanks to an efficient algorithms Bonfiglioli Agile drives can control brushless servo motors without the need of any feedback sensors. With this option the BMD servo motor have no feedback device and the angular position of the motor shaft is estimated from measurements of the current absorbed by the motor.

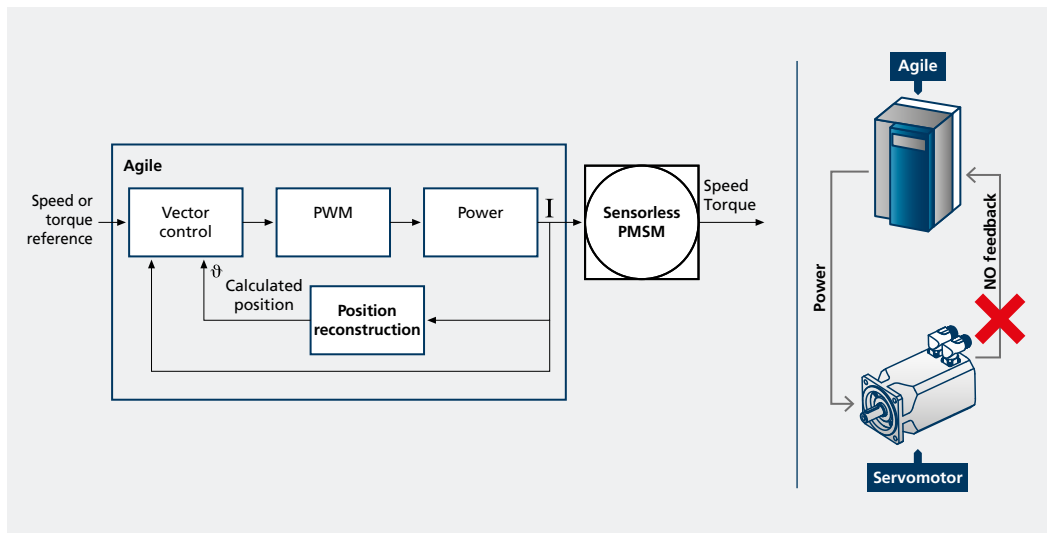

SEN P1/P1N
8-pin power connector

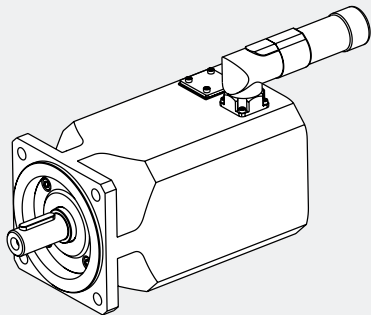

SEN P2
1-meter power cable

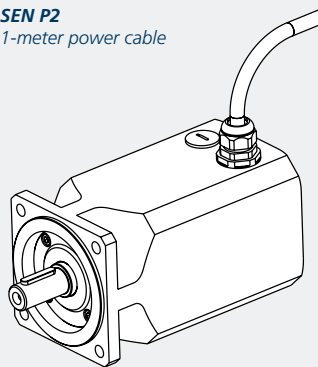

Feedback devices

RESOLVER: [RES1,RES2]

The resolver is an electromagnetic transformer consisting of a stator and a rotor elements excited from an external source. It produces two output signals that correspond to the sine and cosine angle of the motor shaft. This is a robust device of good accuracy, capable of withstanding high temperature and high levels of vibration. Position information is absolute within one turn.

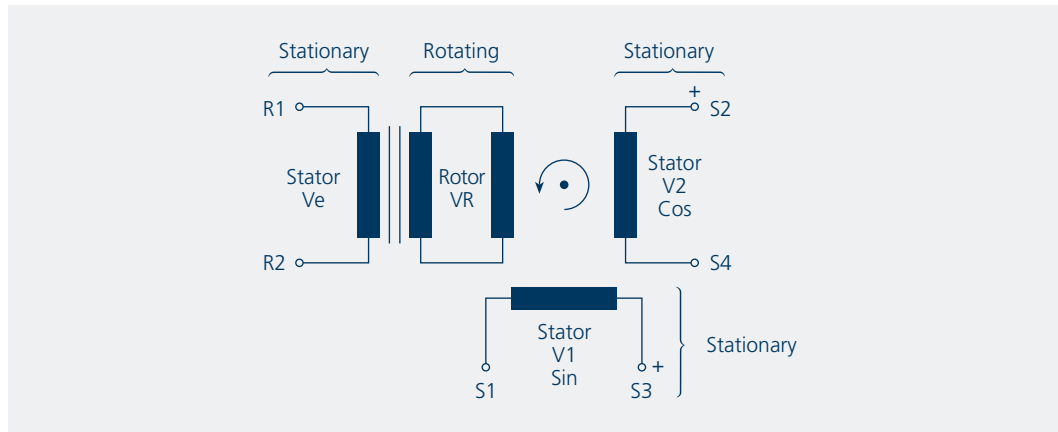

| ITEM | BMD 65 | | BMD82 - BMD170 | |
|--|-------------------|------------------------------------|-------------------|--|
| | RES2 | RES1 | RES2 | |
| Poles number | 2 | 2 | 2 | |
| Transformation ratio | 0.5 ±5% | 0.5 ^{+15%} _{-5%} | 0.5 ±5% | |
| Input voltage [Vac _{rms}] | 7 | 11 | 5.5 | |
| Input current [mA] | 65 | 57 | 61 | |
| Input frequency [kHz] | 10 | 8 | 10 | |
| Phase shift | 0° | -11° | -12° | |
| Input impedance Zro | 70 + j100 | 75 + j185 | 43 + j79 | |
| Output impedance Zss (Ω) | 175 + j275 | 135 + j265 | 62 + j112 | |
| Electrical error | ±10' | ±10' | ±10' | |
| Accuracy ripple | 1' max | 1' max | 1' max | |
| Operating temperature | -55°C ... + 155°C | -55°C ... + 155°C | -55°C ... + 155°C | |
| Max Speed [min ⁻¹] | 10000 | 20000 | 10000 | |
| Mass [kg] | 0.065 | 0.28 | 0.28 | |
| Rotor Inertia [kgm ² x 10 ⁻⁶] | 3.0 | 5.0 | 5.0 | |

Please check the compatibility with our Motion Control with our Technical team or by consulting the Motion Control catalogue.

Optical encoders

The optical absolute encoder use a high precision optical disc to measure the angular position. Single turn absolute encoder has an absolute positional information only within one turn. Multi turn absolute encoder is provided of extra gear wheels that account of several shaft revolution. Therefore the output is unique for each shaft position and revolution up to available revolutions.

HEIDENHAIN ENCODERS

| ITEM | BMD65 | | BMD82 - BMD170 | | |
|--|-------------------------------------|----------------|-------------------------------------|----------------|-------------------------------------|
| | ENB1 | ENB2 | ENB1 | ENB2 | ENB7 |
| Manufacturer | Dr. JOHANNES HEIDENHAIN GmbH | | | | |
| Data interface | EnDat | | EnDat | | SinCos |
| Model | ECN1113 | EQN1125 | ECN1313 | EQN1325 | ERN 1387 |
| Type | Single turn | Multi turn | Single turn | Multi turn | Single turn |
| Measuring principle | Optical | | Optical | | Optical |
| Power supply | 3.6VDC ... 14VDC | | 3.6VDC ... 14VDC | | 5 VDC ±0.5V |
| Current consumption | 85mA (5V) | 105mA (5V) | 85mA (5V) | 105mA (5V) | <120 mA |
| Periods per revolution | 512 | 512 | 2048 | 2048 | 2048 |
| Position per revolution | 8192 (13 bits) | 8192 (13 bits) | 8192 (13 bits) | 8192 (13 bits) | 65536 (16 bits) ⁽¹⁾ |
| Revolutions | - | 4096 (12 bits) | - | 4096 (12 bits) | - |
| Operating temperature | -40°C ... +115°C | | -40°C ... +115°C | | -40°...+120°C |
| Max Speed [min ⁻¹] | 12000 | | 12000 | | 15000 |
| Resistance to shocks | 1000 m/s ² - 6ms | | 2000 m/s ² - 6ms | | 2000 m/s ² - 6ms |
| Resistance to vibrations | 200m/s ² - 55 ... 2000Hz | | 300m/s ² - 55 ... 2000Hz | | 300m/s ² - 55 ... 2000Hz |
| Mass [kg] | 0.10 | | 0.25 | | 0.25 |
| Rotor Inertia [kgm ² x 10 ⁻⁶] | 0.40 | | 2.60 | | 2.6 |

(1) This resolution is obtained when used with the EM-ABS-01 acquisition module.

SICK ENCODERS

| ITEM | BMD65 | | BMD82 - BMD170 | |
|--|-----------------------|----------------|-----------------------|----------------|
| | ENB3 | ENB4 | ENB3 | ENB4 |
| Manufacturer | SICK AG | | | |
| Data interface | Hiperface | | Hiperface | |
| Model | SKS36 | SKM36 | SRS50 | SRM50 |
| Type | Single turn | Multi turn | Single turn | Multi turn |
| Measuring principle | Optical | | Optical | |
| Power supply | 7VDC ... 12VDC | | 7VDC ... 12VDC | |
| Current consumption | 60mA | 60mA | 80mA | 80mA |
| Periods per revolution | 128 | 128 | 1024 | 1024 |
| Position per revolution | 4096 (12 bits) | 4096 (12 bits) | 32768 (15 bit) | 32768 (15 bit) |
| Revolutions | - | 4096 (12 bits) | - | 4096 (12 bits) |
| Operating temperature | -20°C ... +110°C | | -30°C ... +115°C | |
| Max Speed [min ⁻¹] | 10000 | | 12000 | |
| Resistance to shocks | 100 g / 6 ms | | 100 g / 6 ms | |
| Resistance to vibrations | 50 g / 10 ... 2000 Hz | | 20 g / 10 ... 2000 Hz | |
| Mass [kg] | 0.07 | | 0.20 | |
| Rotor Inertia [kgm ² x 10 ⁻⁶] | 0.45 | | 1.00 | |

Please check the compatibility with our Motion Control with our Technical team or by consulting the Motion Control catalogue.

Inductive and Capacitive encoders

The absolute inductive and capacitive encoders available in the BMD series have no integral bearing. The angular position is achieved measuring high-frequency signals for encoder exploiting the inductive measuring principle or with a holistic scanning system for encoder exploiting the capacitive principle of measurement.

HEIDENHAIN ENCODER

| ITEM | | BMD65 - BMD170 |
|--|-------------------------------------|----------------|
| | | ENB8 |
| Manufacturer | Dr. JOHANNES HEIDENHAIN GmbH | |
| Data interface | EnDat | |
| Model | EQI1131 | |
| Type | Multi turn | |
| Measuring principle | Inductive | |
| Power supply | 3.6VDC ... 14VDC | |
| Current consumption | 115mA (5V) | |
| Periods per revolution | - | |
| Position per revolution | 524288 (19 bits) | |
| Revolutions | 4096 (12 bits) | |
| Operating temperature | -40°C ... +115°C | |
| Max Speed [min ⁻¹] | 12000 | |
| Resistance to shocks | 2000 m/s ² - 6ms | |
| Resistance to vibrations | 400m/s ² - 55 ... 2000Hz | |
| Mass [kg] | 0.04 | |
| Rotor Inertia [kgm ² x 10 ⁻⁶] | 0.30 | |

SICK ENCODERS

| ITEM | | BMD65 - BMD170 | |
|--|-----------------------|------------------|------|
| | | ENB5 | ENB6 |
| Manufacturer | SICK AG | | |
| Data interface | Hiperface | | |
| Model | SEK37 | SEL37 | |
| Type | Single turn | Multi turn | |
| Measuring principle | Capacitive | | |
| Power supply | 7VDC ... 12VDC | | |
| Current consumption | 50mA | 50mA | |
| Periods per revolution | 16 | 16 | |
| Position per revolution | 512 (9 bits) | 512 (9 bits) | |
| Revolutions | - | 4096 (12 bits) | |
| Operating temperature | -40°C ... +115°C | -20°C ... +115°C | |
| Max Speed [min ⁻¹] | 120000 | | |
| Resistance to shocks | 100 g / 10 ms | | |
| Resistance to vibrations | 50 g / 10 ... 2000 Hz | | |
| Mass [kg] | 0.04 | | |
| Rotor Inertia [kgm ² x 10 ⁻⁶] | 0.10 | | |

Please check the compatibility with our Motion Control with our Technical team or by consulting the Motion Control catalogue.

Thermal protection

As standard, the BMD motors are equipped with an integrated PTC thermistor to protect the windings against overtemperatures exceeding the limit of the motor class F insulation. Optionally a KTY or a PT1000 sensors are available, to fit any needs for temperature feedback.

| OPTIONS | THERMAL PROTECTOR | NOTE |
|---------|---|---|
| PTC | 1x PTC BMD 65-102 3x PTC BMD 118-170 | The PTC thermistors is placed in contact with the motor winding. The thermistor switch temperature is in accordance with the insulation class F of the motor. |
| KTY | Type KTY 84-130 | A KTY silicon semi-conductor resistance sensor is placed in contact with the motor winding. The working temperature range is from 0°C to 170°C. |
| TC1 | PT1000 | A platinum resistance temperature sensor is place in contact with the motor winding. The PT1000 characteristic is in accordance with IEC 60751 : 2008, tolerance class B. The working temperature is from -40°C to 250°C. |

Electromechanical holding brake - F24 option

An electromagnetic holding brake is available. The brake variant can be ordered by selecting the F24 value in the brake option field.

The electromechanical brake is for use as an holding brake with motor shaft stationary. Do not use it as a dynamic brake, except for emergencies such as main supply failure.

Data of the available brake for each motor size are summarized in the following table.
When the motor is delivered without brake, the brake fitting is not possible.

The brake coil voltage supply must be 24V DC-voltage.
The brake option is responsible of an increment of the motor length.
Brake leads are wired in the power connector together with motor leads.

Please note that the brake option is not available when the "additional inertia" option is selected.

| Motor | Rated brake torque 20°C M_b | Rated brake torque 100°C M_b | Brake voltage V_b | Brake current I_b | Brake power 20°C P_b | Inertia increase ΔJ | Mass increase Δm_M | Engaging time t_1 | Release time t_2 |
|------------|----------------------------------|-----------------------------------|------------------------|------------------------|---------------------------|--------------------------------|-------------------------------|------------------------|-----------------------|
| | Nm | Nm | Vdc | A | W | $Kgm^2 \cdot 10^{-4}$ | kg | ms | ms |
| 65 | 2 | 1.8 | 24 | 0.46 | 11 | 0.068 | 0.2 | 6 | 25 |
| 82 | 4.5 | 4 | | 0.5 | 12 | 0.18 | 0.6 | 7 | 35 |
| 102 | 9 | 8 | | 0.75 | 18 | 0.54 | 1.1 | 7 | 40 |
| 118 | 18 | 15 | | 1.0 | 24 | 1.66 | 2.2 | 10 | 50 |
| 145 | 18 | 15 | | 1.0 | 24 | 1.66 | 2.6 | 10 | 50 |
| 170 | 36 | 32 | | 1.1 | 26 | 5.56 | 4.5 | 22 | 90 |

Notes

t_1 Time from disconnecting the current until the rated torque is attained

t_2 Time from connecting the current until the torque decreases

Additional inertia feature - F1 option

BMD Permanent Magnet AC Synchronous Motor series is provided optionally with additional inertia. The BMD motors with additional inertia have higher rotor moment of inertia in comparison with basic version. Additional inertia is designed to be used in application with high load inertia. The increased rotor moment of inertia provides a comfortable control response due to "higher" inertial matching of the machine.

| MOTOR | INERTIA INCREASE ΔJ Kgm ² · 10 ⁻⁴ | MASS INCREASE Δm_M kg |
|-------|---|-------------------------------------|
| 65 | 0.5 | 0.4 |
| 82 | 3 | 1 |
| 102 | 7.5 | 1.7 |
| 118 | 16 | 3.5 |
| 145 | 36 | 5 |
| 170 | 70 | 8.2 |

Forced ventilation

BMD motors size 145 and 170 can be ordered completed with additional fan unit (forced ventilation IC 416) selecting the proper designation variants (V1R, V1S, V2R, V2S). Motors originally provided with a fan unit have the power and signal connectors rotatable as per standard BMD motors (180° x 90°).

Alternatively, the fan units are available as kit suitable for the retrofit of standard motors. In this case the customer has to modify the existing motor to assembly the fan unit.

The fan cowl is black painted RAL 9005. Fans have metal housing and IP54 degree of protection.

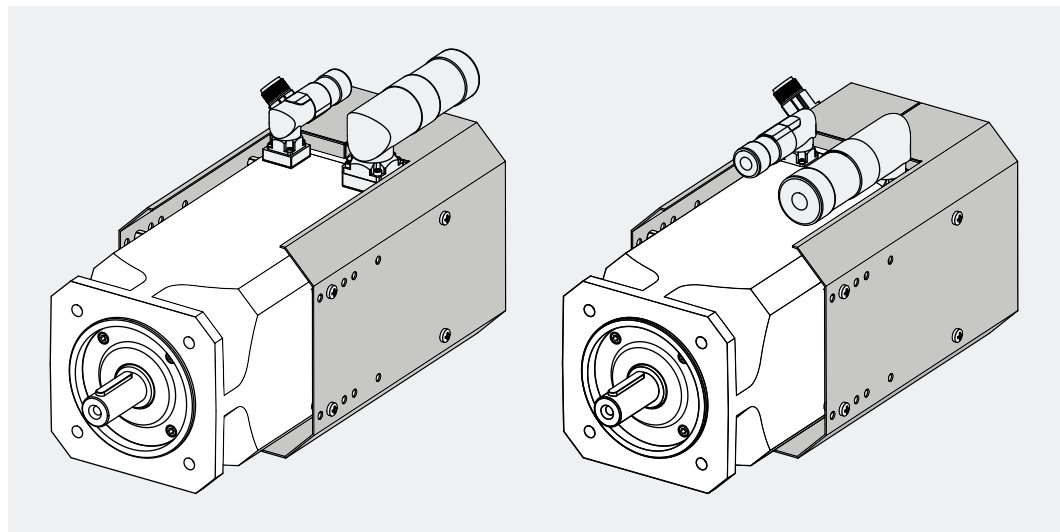

Forced ventilation

KIT ORDER CODES FOR RETROFIT

To install the forced ventilation as a retrofit kit the standard BMD motor housing must be modify adding 8 threaded holes. In this configuration the motor connectors must be oriented to the drive end side and they can not rotate. Instructions for housing modifications are reported in the fan unit operation manual supplied with the kit. For selecting the right ventilation kit refer to the following tables.

| MOTOR VARIANT | | |
|-----------------------|--|---------------------------------|
| | Fan cowl type S | Fan cowl type L |
| BMD 145 16.8 | SEN / RES1 / RES2 / ENB1...ENB8 | - |
| BMD 145 16.8...F24/F1 | SEN / RES1 / RES2 / ENB3...ENB6 / ENB8 | ENB1 / ENB2 / ENB7 |
| BMD 145 22 | SEN / RES1 / RES2 / ENB3...ENB6 / ENB8 | ENB1 / ENB2 / ENB7 |
| BMD 145 22...F24/F1 | - | SEN / RES1 / RES2 / ENB1...ENB8 |
| BMD 170 34 | SEN / RES1 / RES2 / ENB1...ENB8 | - |
| BMD 170 34...F24/F1 | SEN / RES1 / RES2 / ENB3...ENB6 / ENB8 | ENB1 / ENB2 / ENB7 |
| BMD 170 45 | SEN / RES1 / RES2 / ENB1...ENB8 | - |
| BMD 170 45...F24/F1 | - | SEN / RES1 / RES2 / ENB1...ENB8 |

| FAN UNIT VARIANTS AND KIT ORDER CODES | | | | |
|---------------------------------------|----------|-------------|---------------|----------------|
| KIT code | BMD size | Fan voltage | Fan cowl size | Connector type |
| 19MOT0001 | BMD 170 | 24V DC | S | Straight |
| 19MOT0002 | BMD 170 | 24V DC | L | Straight |
| 19MOT0003 | BMD 170 | 230V AC | S | Straight |
| 19MOT0004 | BMD 170 | 230V AC | L | Straight |
| 19MOT0005 | BMD 170 | 24V DC | S | Rotatable |
| 19MOT0006 | BMD 170 | 24V DC | L | Rotatable |
| 19MOT0007 | BMD 170 | 230V AC | S | Rotatable |
| 19MOT0008 | BMD 170 | 230V AC | L | Rotatable |
| 19MOT0009 | BMD 145 | 24V DC | S | Straight |
| 19MOT0010 | BMD 145 | 24V DC | L | Straight |
| 19MOT0011 | BMD 145 | 230V AC | S | Straight |
| 19MOT0012 | BMD 145 | 230V AC | L | Straight |
| 19MOT0013 | BMD 145 | 24V DC | S | Rotatable |
| 19MOT0014 | BMD 145 | 24V DC | L | Rotatable |
| 19MOT0015 | BMD 145 | 230V AC | S | Rotatable |
| 19MOT0016 | BMD 145 | 230V AC | L | Rotatable |

Note

In case of retrofit, check the power cable section. It must be in accordance with the power servocables matching table present in this catalog.

Forced ventilation

FANS ELECTRICAL DATA AND CONNECTION

| FANS ELECTRICAL DATA | | | | |
|----------------------|-------------|---------------|-----------|-----------|
| BMD size | Fan voltage | Voltage range | Power | Frequency |
| BMD 170 | 24V DC | 12...30V DC | 12 W | - |
| | 230V AC | - | 45 / 39 W | 50/ 60 Hz |
| BMD 145 | 24V DC | 12...30V DC | 12 W | - |
| | 230V AC | - | 30 / 28 W | 50/ 60 Hz |

| LAYOUT OF SUPPLY CONNECTORS VXS / VXR AND PRE-ASSEMBLED CABLES | | | |
|--|-----------------|--|--------------|
| PIN | DESCRIPTION | | CABLE LABEL |
| 1 | Not connected | | - |
| 2 | Not connected | | - |
| 3 | Earth | | Yellow-Green |
| 4 | +VDC / Phase | | 1 |
| 5 | - VDC / Neutral | | 2 |
| 6 | Not connected | | - |

CONNECTION ACCESSORIES

| ORDER CODE | DESCRIPTION |
|------------|--|
| 712692054 | Plug connector with pin – Clamping range: 7.5...12mm |
| 712692108 | Plug connector with pin – Clamping range: 4.2...6.6mm |
| 612580269 | Assembled cable with connector MFC 03 C1 – Length: 3m |
| 612580271 | Assembled cable with connector MFC 05 C1 – Length: 5m |
| 612580272 | Assembled cable with connector MFC 10 C1 – Length: 10m |

Connections

The power and feedback device connections can be made by angled rotatable receptacles connector (P1N S1N or P1 S1) or by straight turning receptacles connector (P3N S3N or P3 S3) or by 1 metre flying cable (P2, S2 or S2C).

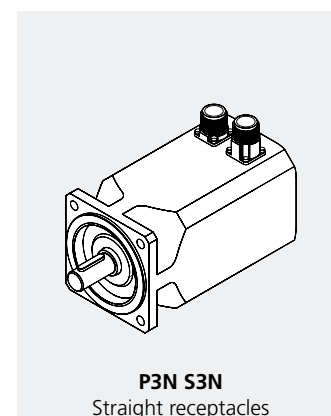
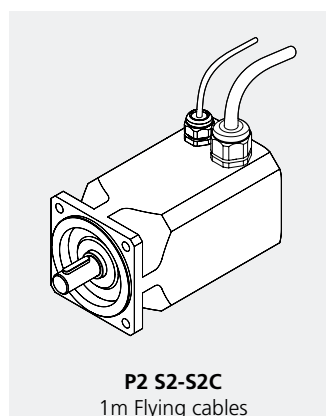
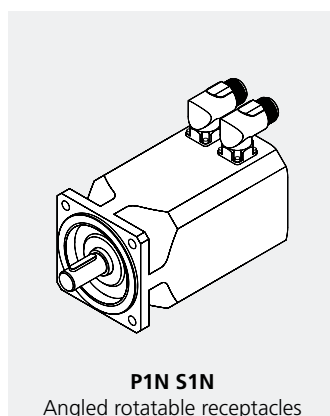

Power connections

The 6-pin power connector of the motor with feedback includes the pins of the motor supply and the ones for the brake supply (if provided). The sensorless motor has 8-pin power connector and include also the pins for the thermal protection. Same layouts are used for motor with flying cable connection.

| MOTOR WITH FEEDBACK DEVICE / BMD65 - BMD145 | | |
|--|-------------|-------------------------|
| Power connector layout (P1N/P1/P3N/P3 options) | | Power cable (P2 option) |
| Connector PIN number | Description | Cable label or color |
| 1 | Phase U | L1 / 1 / U |
| 2 | Phase V | L2 / 2 / V |
| \perp | Earth - SL | Yellow - Green |
| 4 | Brake + | White |
| 5 | Brake - | Black |
| 6 | Phase W | L3 / 3 / W |

| MOTOR WITH FEEDBACK DEVICE / BMD170 | | |
|--|-------------|-------------------------|
| Power connector layout (P1N/P1/P3N/P3 options) | | Power cable (P2 option) |
| Connector PIN number | Description | Cable label or color |
| U | Phase U | L1 / 1 / U |
| V | Phase V | L2 / 2 / V |
| W | Phase W | L3 / 3 / W |
| \perp | Earth - SL | Yellow - Green |
| + | Brake + | White |
| - | Brake - | Black |

| SENSORLESS MOTOR / BMD65 - BMD145 | | |
|--|---------------------|-------------------------|
| Power connector layout (P1N/P1/P3N/P3 options) | | Power cable (P2 option) |
| Connector PIN number | Description | Cable label or color |
| 1 | Phase U | L1 / 1 / U |
| \perp | Earth - SL | Yellow - Green |
| 3 | Phase W | L3 / 3 / W |
| 4 | Phase V | L2 / 2 / V |
| A | Thermal protector + | White / 5 |
| B | Thermal protector - | Black / 6 |
| C | Brake + | 7 |
| D | Brake - | 8 |

| SENSORLESS MOTOR / BMD170 | | |
|--|---------------------|-------------------------|
| Power connector layout (P1N/P1/P3N/P3 options) | | Power cable (P2 option) |
| Connector PIN number | Description | Cable label or color |
| U | Phase U | L1 / 1 / U |
| V | Phase V | L2 / 2 / V |
| W | Phase W | L3 / 3 / W |
| \perp | Earth - SL | Yellow - Green |
| 1 | Thermal protector + | White / 5 |
| 2 | Thermal protector - | Black / 6 |
| + | Brake + | 7 |
| - | Brake - | 8 |

Signal connections

The signal connector gathers the feedback device signals and the thermal protection terminal. Each feedback device has proper signal connector layout. Variants with flying cable have different termination on the inverter feedback module side. S2 variant has lead wires with ferrules for connection to scree terminals. S2C variant has SUB-D male standard connector with layout in accordance with the Bonfiglioli interface module.

| MOTOR WITH RESOLVER (RES1/RES2) / BMD65 - BMD170 | | |
|--|---------------------|-------------------------------|
| Signal connector layout (S1N/S1/S3N/S3 options) | | Signal cable (S2 option) |
| Connector PIN number | Description | Cable color |
| 1 | Sin - | Brown |
| 2 | Sin + | Green |
| 3 | n.c. | not connected |
| 4 | Shield cable | - |
| 5 | n.c. | not connected |
| 6 | n.c. | not connected |
| 7 | Exct - | Black |
| 8 | Thermal protector - | White (0.50 mm ²) |
| 9 | Thermal protector + | Brown (0.50 mm ²) |
| 10 | Exct + | Red |
| 11 | Cos + | Gray |
| 12 | Cos - | Rose |

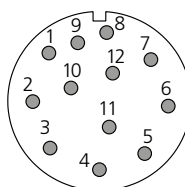

| MOTOR WITH ENDAT ENCODER (ENB1/ENB2/ENB8) / BMD65 - BMD170 | | |
|--|---------------------|-------------------------------|
| Signal connector layout (S1N/S1/S3N/S3 options) | | Signal cable (S2 option) |
| Connector PIN number | Description | Cable color |
| 1 | UP SENSOR | Violet |
| 2 | n.c. | not connected |
| 3 | n.c. | not connected |
| 4 | 0V SENSOR | Yellow |
| 5 | Thermal protector - | Blue (0.50 mm ²) |
| 6 | Thermal protector + | White (0.50 mm ²) |
| 7 | UP | White Green |
| 8 | Clock + | Blue |
| 9 | Clock - | Black |
| 10 | 0V | Brown Green |
| 11 | Shield cable | - |
| 12 | B + ⁽¹⁾ | Red Black ⁽²⁾ |
| 13 | B - ⁽¹⁾ | Green Black ⁽²⁾ |
| 14 | DATA + | Gray |
| 15 | A + ⁽¹⁾ | Blue Black ⁽²⁾ |
| 16 | A - ⁽¹⁾ | Yellow Black ⁽²⁾ |
| 17 | DATA - | Rose |

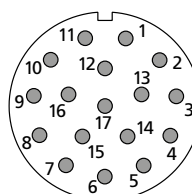

Note

(1) Signals not available for encoder ENB8

(2) Wires to be cut for cable MSC - EN1 FW in case of encoder ENB8

Signal connections

| MOTOR WITH HYPERFACE ENCODER (ENB3/ENB4/ENB5/ENB6) / BMD65 - BMD170 | | |
|---|---------------------|-------------------------------|
| Signal connector layout (S1N/S1/S3N/S3 options) | | Signal cable (S2 option) |
| Connector PIN number | Description | Cable color |
| 1 | Sin + | Green |
| 2 | Sin - | Brown |
| 3 | RS485 + | Blue |
| 4 | n.c. | not connected |
| 5 | Shield cable | - |
| 6 | n.c. | not connected |
| 7 | GND (0V) | Black |
| 8 | Thermal protector - | White (0.50 mm ²) |
| 9 | Thermal protector + | Brown (0.50 mm ²) |
| 10 | + Vdc | Red |
| 11 | Cos + | Gray |
| 12 | Cos - | Rose |
| 13 | RS485 - | Violet |
| 14 | n.c. | not connected |
| 15 | n.c. | not connected |
| 16 | n.c. | not connected |
| 17 | n.c. | not connected |

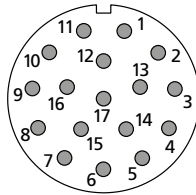

| MOTOR WITH SINCOS ENCODER (ENB7) / BMD82 - BMD170 | | |
|---|---------------------|-------------------------------|
| Signal connector layout (S1N/S1/S3N/S3 options) | | Signal cable (S2 option) |
| Connector PIN number | Description | Cable color |
| 1 | Sin + | Blue Black |
| 2 | Sin - | Yellow Black |
| 3 | R+ | Blue |
| 4 | D- | Brown |
| 5 | C+ | Gray |
| 6 | C- | Rose |
| 7 | OVL SENSOR | Yellow |
| 8 | Thermal protector + | White (0.50 mm ²) |
| 9 | Thermal protector - | Blue (0.50 mm ²) |
| 10 | Vencs | White Green |
| 11 | Cos + | Red Black |
| 12 | Cos - | Green Black |
| 13 | R - | Black |
| 14 | D + | Green |
| 15 | OVL | Brown Green |
| 16 | Venc | Violet |
| 17 | Shield cable | - |

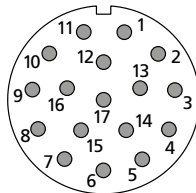

Servocables

The word servocable is referred to electrical cable connecting Bonfiglioli servomotor to respective inverter.

A servocables selection is available for power supply and sensor feed-back, justifying the distinction between power cables and signal cables.

The power cable provides energy to motor, but also feeds the brake when present.

The signal cables instead are in charge of transmission of electrical signals generated by feed-back equipment installed on the motor. The same cable is also used to convey the thermal protection.

All servocables are available in three different and fixed lengths (3 meters, 5 m, 10 m) offering to user an exhaustive proposal to numerous needs of configuration.

Other lengths available on request.

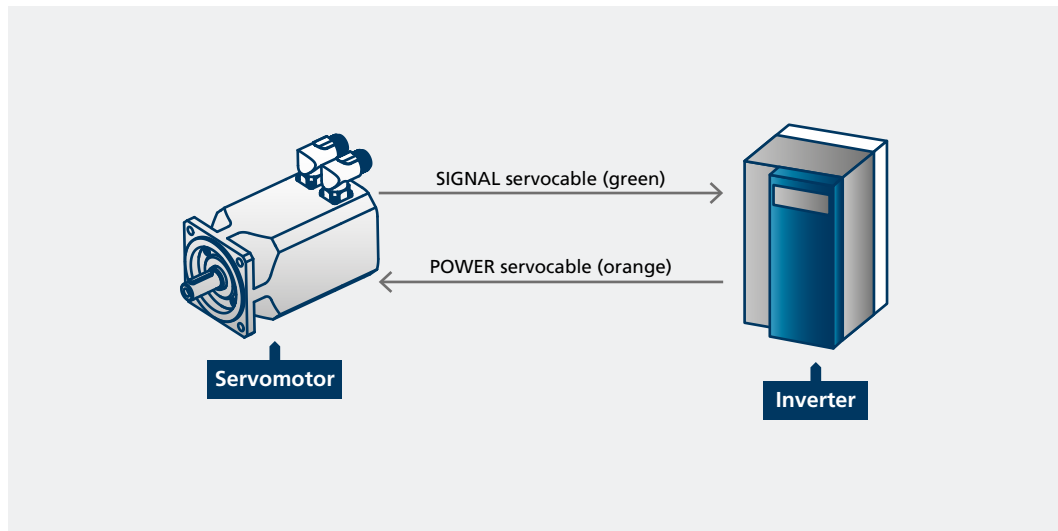

Servocables

Power servocables

Power cables are recognized by the orange color according to Desina standard. The conductors cross-section depends on the motor nominal current. In order to face different current level absorbed by different motor sizes, the power cables are executed with four conductors cross sections (1.5 mm², 2.5 mm², 4.0 mm², 10.0 mm²). On inverter side, every cable terminates with flying leads covered by ferrules for plug-in into screw terminals. On motor side the cable is equipped with metal circular plug with Speed-Tech technology for easy and sure plug-in with corresponding motor rotatable receptacle. According to page 52, power connectors have 6 pins for motor with feedback and 8 pins for sensorless motor variants.



The power cables fulfil the following technical requirements:

| TECHNICAL DATA | |
|-------------------------------|---|
| Properties | Oil resistant shielded cable for dynamic laying |
| Conductor | Tinned Stranded Cu wire complying with IEC 60228 Cl 5 / 6 |
| Outer Sheath | PUR or equivalent thermoplastic material - Color: orange RAL 2003 |
| Inner Sheath | PP or TPE |
| Tinned Cu braid Shield | Coverage overall screen > 80% |

| ELECTRICAL DATA | |
|-----------------------------|-----------------------------|
| Nom. Volt. Power cores | U ₀ /U 600/1000V |
| Nom. Volt. Control cores | U ₀ /U 300/500V |
| AC Test Volt. Power cores | 4 kV |
| AC Test Volt. Control cores | 1 kV |
| Insulation Resistance | > 5 MOhm/km |

| MECHANICAL DATA | |
|------------------------|-----------------------|
| Service Temperature | -15 / +80 °C |
| Minimum Bending Radius | 10 x D |
| N° bending cycles | ≥ 10 ⁶ |
| Max Speed | ≥ 180 m/min |
| Max Acceleration | ≥ 15 m/s ² |

STANDARD AND CERTIFICATIONS

UL/CSA, RoHS, DESINA

The cable ordering code is structured in the following mode with five fields:

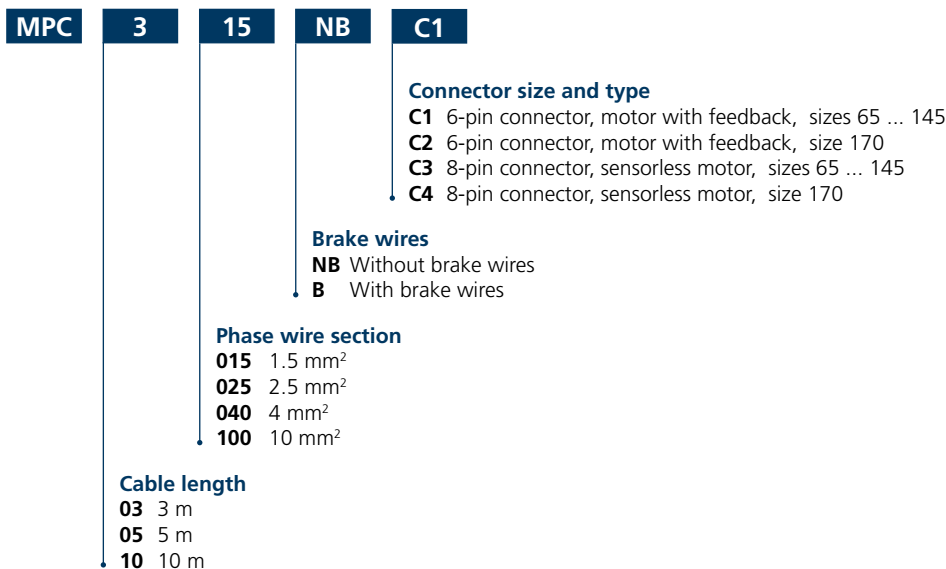

Power servocables

For helping the user during servomotor-cable selection, the following matching tables are proposed. Field XX refers to the cable length (03, 05, 10), while field YY refers to the brake variant (NB, B): see previous page for fields description.

| SIZE | STALL TORQUE Nm | NOMINAL SPEED | | | | |
|--|--------------------|------------------------|------------------------|------------------------|------------------------|------------------------|
| | | 1600 min ⁻¹ | 3000 min ⁻¹ | 4500 min ⁻¹ | 5500 min ⁻¹ | 6000 min ⁻¹ |
| 400V NOMINAL VOLTAGE – MOTOR WITH FEEDBACK | | | | | | |
| 65 | - | | | | | |
| 82 | - | | | | | |
| 102 | - | | | MPC XX 015 YY C1 | | |
| 118 | 5,6 | | | | | |
| | 10,2 | | | | | |
| 145 | 14 | | | MPC XX 025 YY C1 | | |
| | 16,8 | | | | | |
| 170 | 22 | | | MPC XX 040 YY C1 | | |
| | 34 | MPC XX 040 YY C2 | | | | |
| | 45 | | MPC XX 100 YY C2 | | | Not available |
| 400V NOMINAL VOLTAGE – SENSORLESS MOTOR WITH CONNECTOR | | | | | | |
| 65 | - | | | | | |
| 82 | - | | | | | |
| 102 | - | | | MPC XX 015 YY C3 | | |
| 118 | 5,6 | | | | | |
| | 10,2 | | | | | |
| 145 | 14 | | | MPC XX 025 YY C3 | | |
| | 16,8 | | | | | |
| 170 | 22 | | | MPC XX 040 YY C3 | | |
| | 34 | MPC XX 040 YY C4 | | | | |
| | 45 | | MPC XX 100 YY C4 | | | Not available |
| 230V NOMINAL VOLTAGE – MOTOR WITH FEEDBACK | | | | | | |
| 65 | - | | | | | |
| 82 | - | | | | | |
| 102 | 4 | | | MPC XX 015 YY C1 | | |
| | 7,2 | | | | | |
| 118 | 9,6 | | | | | |
| | 5,6 | | | | | |
| 145 | 10,2 | | | MPC XX 025 YY C1 | | |
| | 14 | | | | | |
| 170 | 16,8 | | | | | |
| | 22 | MPC XX 025 YY C1 | MPC XX 040 YY C1 | | | Not available |
| | 34 | MPC XX 040 YY C2 | MPC XX 100 YY C2 | | | |
| 230V NOMINAL VOLTAGE – SENSORLESS MOTOR WITH CONNECTOR | | | | | | |
| 65 | - | | | | | |
| 82 | - | | | | | |
| 102 | 4 | | | MPC XX 015 YY C3 | | |
| | 7,2 | | | | | |
| 118 | 9,6 | | | | | |
| | 5,6 | | | | | |
| 145 | 10,2 | | | MPC XX 025 YY C3 | | |
| | 14 | | | | | |
| 170 | 16,8 | | | | | |
| | 22 | MPC XX 025 YY C3 | MPC XX 040 YY C3 | | | Not available |
| | 34 | MPC XX 040 YY C4 | MPC XX 100 YY C4 | | | |
| 400V NOMINAL VOLTAGE – MOTOR WITH FEEDBACK AND FORCED VENTILATION | | | | | | |
| 145 | 21,5 | | | | | |
| | 27,5 | MPC XX 015 YY C1 | MPC XX 025 YY C1 | MPC XX 040 YY C1 | | |
| 170 | 44 | | | | | |
| | 60 | MPC XX 040 YY C2 | MPC XX 100 YY C2 | | | Not available |
| 400V NOMINAL VOLTAGE – SENSORLESS MOTOR WITH CONNECTOR AND FORCED VENTILATION | | | | | | |
| 145 | 21,5 | | | | | |
| | 27,5 | MPC XX 015 YY C3 | MPC XX 025 YY C3 | MPC XX 040 YY C3 | | |
| 170 | 44 | | | | | |
| | 60 | MPC XX 040 YY C4 | MPC XX 100 YY C4 | | | Not available |
| 230V NOMINAL VOLTAGE – MOTOR WITH FEEDBACK AND FORCED VENTILATION | | | | | | |
| 145 | 21,5 | | | | | |
| | 27,5 | MPC XX 025 YY C1 | MPC XX 040 YY C1 | | | Not available |
| 170 | 44 | | | | | |
| | | | MPC XX 100 YY C2 | | | |
| 230V NOMINAL VOLTAGE – MOTOR WITH FEEDBACK AND FORCED VENTILATION | | | | | | |
| 145 | 21,5 | | | | | |
| | 27,5 | MPC XX 025 YY C3 | MPC XX 040 YY C3 | | | Not available |
| 170 | 44 | | | | | |
| | | | MPC XX 100 YY C4 | | | |

Signal servocables

Signal cables are recognized by the green color according to Desina standard. The conductors number, their cross-section and their terminal type depend by the transducer typology supported by the cable.

Cables are available for connection of every feedback option, either resolver and absolute encoders. On motor side, the cable is equipped with metal circular plug with Speed-Tech technology for an easy and sure plug-in with respective rotatable receptacle present on motor.

On inverter side the cable end can be executed with two different terminations:

- with SUB-D male standard connector for easy and sure plug-in with corresponding SUB-D female of the module interface.
- with ferrules for connection to screw terminals of the module interface.

Connections layouts are dedicated to Bonfiglioli Vectron Active Cube interface modules.



Inverter side Motor side

The signal cables fulfil the following technical requirements:

TECHNICAL DATA

| | |
|-------------------------------|--|
| Properties | Oil resistant shielded cable for dynamic laying |
| Conductor | Tinned Stranded Cu wire complying with IEC 60228 Cl 5 / 6 |
| Outer Sheath | PUR or equivalent thermoplastic material - Color: green RAL 6018 |
| Inner Sheath | PP or TPE |
| Tinned Cu braid Shield | Coverage overall screen > 80% |

ELECTRICAL DATA

| | |
|---------------------------|--------------|
| Nominal Voltage | 30 V |
| AC Test Voltage | 1500 V |
| Insulation Resistance | > 10 MOhm/km |
| Capacitance strand/strand | < 150 pF/m |

MECHANICAL DATA

| | |
|------------------------|-----------------------|
| Service Temperature | -20 / +80 °C |
| Minimum Bending Radius | 10 x D |
| N° bending cycles | ≥ 10 ⁶ |
| Max Speed | ≥ 180 m/min |
| Max Acceleration | ≥ 15 m/s ² |

STANDARD AND CERTIFICATIONS

UL/CSA, RoHS, DESINA

The ordering codes of the signal cables are described in the following table:

| FEEDBACK DEVICE | INVERTER SIDE TERMINATION | INVERTER FEEDBACK MODULE | CABLE LENGTH | | |
|---------------------------|---------------------------|--------------------------|---------------|---------------|---------------|
| | | | 3 m | 5m | 10 m |
| RES1 / RES2 | Flying leads | EM-RES-01/02 - EM-AUT-XX | MSC 03 RES FW | MSC 05 RES FW | MSC 10 RES FW |
| | SUB-D9 | EM-RES-03 | MSC 03 RES SC | MSC 05 RES SC | MSC 10 RES SC |
| ENB1 / ENB2 / ENB8 | HD SUB-D15 | EM-ABS-01 - EM-AUT-XX | MSC 03 EN1 SC | MSC 05 EN1 SC | MSC 10 EN1 SC |
| | Flying leads | - | MSC 03 EN1 FW | MSC 05 EN1 FW | MSC 10 EN1 FW |
| ENB3 ... ENB6 | SUB-D15 | EM-ABS-01 - EM-AUT-XX | MSC 03 EN3 SC | MSC 05 EN3 SC | MSC 10 EN3 SC |
| | Flying leads | - | MSC 03 EN3 FW | MSC 05 EN3 FW | MSC 10 EN3 FW |
| ENB7 | SUB-D15 | EM-ABS-01 | MSC 03 EN7 SC | MSC 05 EN7 SC | MSC 10 EN7 SC |
| | Flying leads | - | MSC 03 EN7 FW | MSC 05 EN7 FW | MSC 10 EN7 FW |

Power cable layout

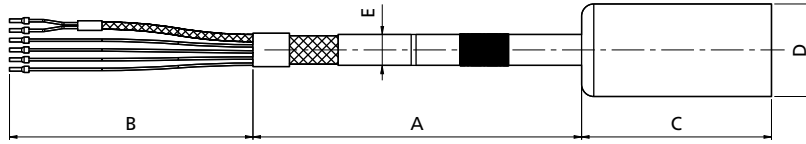

Signal cable layout

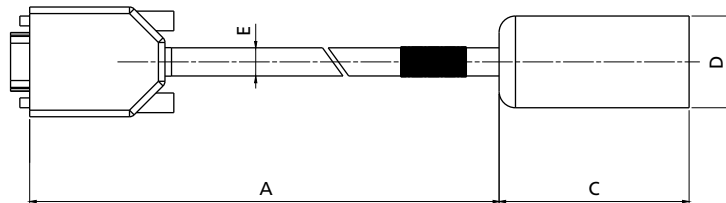
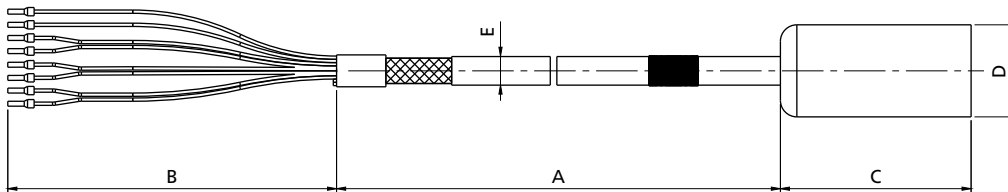

| CONNECTOR SIZE | | A | B | C | D |
|----------------|---------|--|------|------|------|
| | | [m] | [mm] | [mm] | [mm] |
| Power Cable | C1 / C3 | 3 - 5 - 10 according to designation | 150 | 76 | 28 |
| | C2 / C4 | | | 93 | 46 |
| Signal Cable | - | 3 - 5 - 10 according to designation | 150 | 76 | 28 |

| | WIRE SECTION | BRAKE OPTION | E _{max} |
|-------------|--------------------|--------------|------------------|
| | [mm ²] | | [mm] |
| Power Cable | 1.5 | NB | 11.6 |
| | | B | 12.8 |
| | 2.5 | NB | 13 |
| | | B | 14.2 |
| | 4 | NB | 14.7 |
| | | B | 16.3 |
| 10 | NB | 19.7 | |
| | B | 21.8 | |

| | FEEDBACK DESIGNATION | E |
|--------------|----------------------|------|
| | | [mm] |
| Signal Cable | RES | 8.6 |
| | EN1 / EN7 | 8.7 |
| | EN3 | 8.6 |

Power and signal cable marking follows the label and wire colors reported in the pages 58, 59 and 60.

Servo gearheads

Motion application requires the use of precision planetary gearboxes to adapt speeds and torques, while ensuring the precision demanded by the application.

Bonfiglioli Riduttori has chosen to use planetary gearboxes with the BMD range of servo motors.

Bonfiglioli precision planetary gearboxes (PPG) match with BMD Permanent Magnet synchronous motors and provide industrial motion control equipment with torque multiplication and proper inertial matching.

These gearheads combined with powerful drive electronics are designed for servo applications requiring highest standards in terms of dynamics, precision, robustness, durability, and long trouble-free operation.

Low backlash at a competitive price.

The LC and SL Series of planetary gearboxes are characterized by low backlash, silent running and easy motor coupling.

High precision for excellent results.

The MP Series of low backlash planetary gearboxes is characterized by a wide range of mounting configurations, silent running, and superbly easy motor coupling.

Maximum precision for highly dynamic applications.

The TQ and TQF Series of precision planetary gearboxes are designed to deliver the highest level of transmission precision. Low backlash combined with a high torsional stiffness guarantees a very performing product, for in high dynamic and reversing applications. The technical design of this gearbox also allows high axial and radial loads on the output shaft.

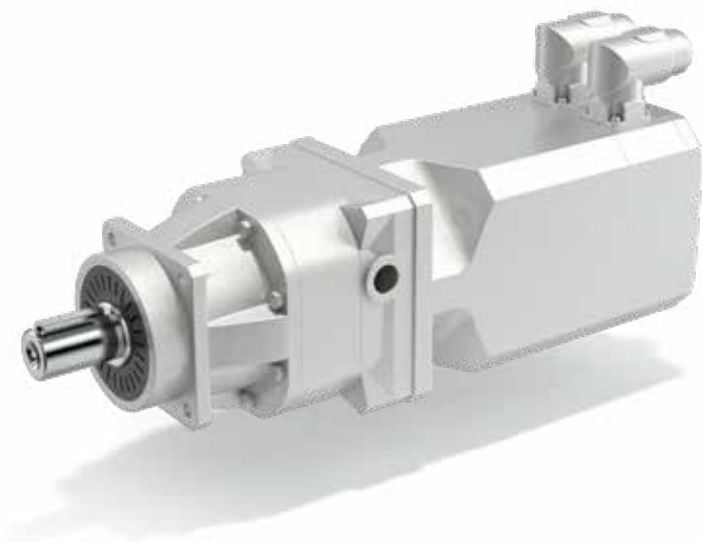

BMD Servomotor / LC series Precision Planetary Gearbox combination

RATIOS FROM 3:1 TO 70:1

| TYPE | MOTOR STALL TORQUE | RATIOS | | | | | | | | | | | MOTOR INERTIA |
|---------|--------------------|------------------|------------------|------------------|------------------|------------------|------------------|------------------|------------------|------------------|------------------|--------|-------------------------------------|
| | [Nm] | 3:1 | 4:1 | 5:1 | 7:1 | 10:1 | 16:1 | 20:1 | 25:1 | 40:1 | 50:1 | 70:1 | kgm ² x 10 ⁻³ |
| BMD 65 | 0.85 | | LC 050 | LC 050 | LC 050 | LC 050 LC 070 | LC 090 | LC 090 | LC 090 | LC 090 LC 120 | LC 090 LC 120 | LC 120 | 0,02 |
| | 1.7 | LC 050 LC 070 | LC 050 LC 070 | LC 050 LC 070 | LC 070 LC 090 | LC 070 LC 090 | LC 090 | LC 090 LC 120 | LC 090 LC 120 | LC 120 LC 120 | LC 120 | | 0,04 |
| | 2.2 | LC 050 LC 070 | LC 050 LC 070 | LC 050 LC 070 | LC 070 LC 090 | LC 090 | LC 090 | LC 090 LC 120 | LC 120 | LC 120 | LC 120 | | 0,06 |
| BMD 82 | 3.2 | LC 050 LC 070 | LC 070 LC 090 | LC 070 LC 090 | LC 070 LC 090 | LC 090 LC 120 | LC 120 | LC 120 | LC 120 LC 155 | LC 155 | LC 155 | LC 155 | 0,14 |
| | 4.4 | LC 070 LC 090 | LC 070 LC 090 | LC 070 LC 090 | LC 070 LC 090 | LC 120 | LC 120 | LC 120 | LC 120 LC 155 | LC 155 | LC 155 | LC 155 | 0,17 |
| BMD 102 | 4.0 | LC 070 LC 090 | LC 070 LC 090 | LC 070 LC 090 | LC 070 LC 090 | LC 120 | LC 120 | LC 120 | LC 120 LC 155 | LC 155 | LC 155 | LC 155 | 0,19 |
| | 7.2 | LC 090 | LC 090 | LC 090 LC 120 | LC 120 | LC 120 LC 155 | LC 155 | LC 155 | LC 155 | | | | 0,34 |
| | 9.6 | LC 090 | LC 090 | LC 090 LC 120 | LC 120 | LC 155 | LC 155 | LC 155 | LC 155 | | | | 0,47 |
| BMD 118 | 5.6 | LC 070 LC 090 | LC 070 LC 090 | LC 090 | LC 090 LC 120 | LC 120 | LC 120 LC 155 | LC 120 LC 155 | LC 155 | LC 155 | LC 155 | | 0,45 |
| | 10.2 | LC 090 LC 120 | LC 120 | LC 120 | LC 120 | LC 155 | LC 155 | LC 155 | LC 155 | | | | 0,78 |
| | 14.0 | LC 120 | LC 120 | LC 120 | LC 120 | LC 155 | LC 155 | LC 155 | | | | | 0,99 |
| BMD 145 | 16.8 | LC 120 | LC 120 | LC 120 LC 155 | LC 155 | LC 155 | LC 155 | | | | | | 1,28 |
| | 22.0 | LC 120 | LC 120 | LC 120 LC 155 | LC 155 | LC 155 | | | | | | | 1,76 |
| BMD 170 | 34.0 | LC 155 | LC 155 | LC 155 | LC 155 | | | | | | | | 3,38 |
| | 45.0 | LC 155 | LC 155 | LC 155 | | | | | | | | | 4,75 |

| DISTRIBUTION OF GEARBOX OUTPUT TORQUE [Nm] | | | | | | | | | | | |
|--|-----|-----|-----|-----|-----|-----|-----|-----|-----|-----|-----|
| | 3 | 4 | 5 | 7 | 10 | 16 | 20 | 25 | 40 | 50 | 70 |
| LC 050 | 10 | 12 | 12 | 12 | - | 12 | 12 | 12 | - | - | - |
| LC 070 | 18 | 25 | 25 | 25 | 18 | 25 | 25 | 25 | 25 | 25 | 25 |
| LC 090 | 37 | 43 | 43 | 43 | 37 | 43 | 43 | 43 | 43 | 43 | 43 |
| LC 120 | 95 | 110 | 110 | 110 | 95 | 110 | 110 | 110 | 110 | 110 | 110 |
| LC 155 | 250 | 300 | 300 | 300 | 250 | 300 | 300 | 300 | 300 | 300 | 300 |

Notes:

Input speed lower than 3000 min⁻¹.

Safety factor 1 < S ≤ 4.

For any additional technical information about gearboxes selection see relevant catalogues.

BMD Servomotor / SL series Precision Planetary Flanged Gearbox combination

RATIOS FROM 3:1 TO 70:1

| TYPE | MOTOR STALL TORQUE | RATIOS | | | | | | | | | | | MOTOR INERTIA |
|----------------|-----------------------|--------|--------|--------|--------|--------|--------|--------|--------|--------|--------|--------|-------------------------------------|
| | [Nm] | 3:1 | 4:1 | 5:1 | 7:1 | 10:1 | 16:1 | 20:1 | 25:1 | 40:1 | 50:1 | 70:1 | kgm ² x 10 ⁻³ |
| BMD 65 | 0.85 | | | | | SL 070 | SL 090 | SL 090 | SL 090 | SL 090 | SL 090 | SL 120 | 0,02 |
| | 1.7 | SL 070 | SL 070 | SL 070 | SL 070 | SL 070 | SL 090 | SL 090 | SL 090 | SL 120 | SL 120 | SL 120 | 0,04 |
| | 2.2 | SL 070 | SL 070 | SL 070 | SL 070 | SL 090 | SL 090 | SL 090 | SL 120 | SL 120 | SL 120 | SL 120 | 0,06 |
| BMD 82 | 3.2 | SL 070 | SL 070 | SL 070 | SL 070 | SL 090 | SL 120 | SL 120 | SL 120 | | | | 0,14 |
| | 4.4 | SL 070 | SL 070 | SL 070 | SL 070 | SL 120 | SL 120 | SL 120 | SL 120 | | | | 0,17 |
| BMD 102 | 4.0 | SL 070 | SL 070 | SL 070 | SL 070 | SL 120 | SL 120 | SL 120 | SL 120 | | | | 0,19 |
| | 7.2 | SL 090 | SL 090 | SL 090 | SL 120 | SL 120 | | | | | | | 0,34 |
| | 9.6 | SL 090 | SL 090 | SL 090 | SL 120 | | | | | | | | 0,47 |
| BMD 118 | 5.6 | SL 070 | SL 070 | SL 090 | SL 090 | SL 120 | SL 120 | SL 120 | | | | | 0,45 |
| | 10.2 | SL 090 | SL 120 | SL 120 | SL 120 | | | | | | | | 0,78 |
| | 14.0 | SL 120 | SL 120 | SL 120 | SL 120 | | | | | | | | 0,99 |
| BMD 145 | 16.8 | SL 120 | SL 120 | SL 120 | | | | | | | | | 1,28 |
| | 22.0 | SL 120 | SL 120 | SL 120 | | | | | | | | | 1,76 |

| DISTRIBUTION OF GEARBOX OUTPUT TORQUE [Nm] | | | | | | | | | | | |
|--|----|-----|-----|-----|----|-----|-----|-----|-----|-----|-----|
| | 3 | 4 | 5 | 7 | 10 | 16 | 20 | 25 | 40 | 50 | 70 |
| SL 070 | 18 | 25 | 25 | 25 | 18 | 25 | 25 | 25 | 25 | 25 | 25 |
| SL 090 | 37 | 43 | 43 | 43 | 37 | 43 | 43 | 43 | 43 | 43 | 43 |
| SL 120 | 95 | 110 | 110 | 110 | 95 | 110 | 110 | 110 | 110 | 110 | 110 |

Notes:

Input speed lower than 3000 min⁻¹.

Safety factor 1 < S ≤ 4.

For any additional technical information about gearboxes selection see relevant catalogues.

BMD Servomotor / MP-TR series Precision Planetary Gearbox combination

RATIOS FROM 3:1 TO 70:1

| TYPE | MOTOR STALL TORQUE | RATIOS | | | | | | | | | | | | MOTOR INERTIA |
|---------|--------------------|------------------------|------------------------|------------------------|------------------------|------------------------|-----------|-----------|-----------|-----------|-----------|-----------|-----------|-------------------------------------|
| | [Nm] | 3:1 | 4:1 | 5:1 | 6:1 | 7:1 | 10:1 | 16:1 | 20:1 | 25:1 | 40:1 | 50:1 | 70:1 | kgm ² x 10 ⁻³ |
| BMD 65 | 0.85 | | | MP-TR 053 | MP-TR 053 | MP-TR 053 | | MP-TR 053 | MP-TR 053 | MP-TR 060 | MP-TR 080 | MP-TR 080 | MP-TR 080 | 0.02 |
| | 1.7 | MP-TR 053 MP-TR 060 | MP-TR 053 MP-TR 060 | MP-TR 053 MP-TR 060 | MP-TR 053 MP-TR 060 | MP-TR 053 MP-TR 060 | MP-TR 060 | MP-TR 060 | MP-TR 080 | MP-TR 080 | MP-TR 080 | MP-TR 105 | MP-TR 105 | 0.04 |
| | 2.2 | MP-TR 053 MP-TR 060 | MP-TR 053 MP-TR 060 | MP-TR 053 MP-TR 060 | MP-TR 053 MP-TR 060 | MP-TR 053 MP-TR 060 | MP-TR 060 | MP-TR 080 | MP-TR 080 | MP-TR 080 | MP-TR 080 | MP-TR 105 | MP-TR 105 | 0.06 |
| BMD 82 | 3.2 | MP-TR 053 MP-TR 060 | MP-TR 053 MP-TR 060 | MP-TR 060 MP-TR 080 | MP-TR 060 MP-TR 080 | MP-TR 060 MP-TR 080 | MP-TR 080 | MP-TR 105 | MP-TR 105 | MP-TR 105 | MP-TR 105 | MP-TR 130 | MP-TR 160 | 0.14 |
| | 4.4 | MP-TR 060 MP-TR 080 | MP-TR 060 MP-TR 080 | MP-TR 060 MP-TR 080 | MP-TR 060 MP-TR 080 | MP-TR 060 MP-TR 080 | MP-TR 080 | MP-TR 105 | MP-TR 105 | MP-TR 105 | MP-TR 105 | MP-TR 130 | MP-TR 160 | 0.17 |
| BMD 102 | 4.0 | MP-TR 060 MP-TR 080 | MP-TR 060 MP-TR 080 | MP-TR 060 MP-TR 080 | MP-TR 060 MP-TR 080 | MP-TR 060 MP-TR 080 | MP-TR 080 | MP-TR 105 | MP-TR 105 | MP-TR 105 | MP-TR 105 | MP-TR 130 | MP-TR 160 | 0.19 |
| | 7.2 | MP-TR 080 | MP-TR 080 | MP-TR 080 | MP-TR 080 MP-TR 105 | MP-TR 080 MP-TR 105 | MP-TR 105 | MP-TR 105 | MP-TR 105 | MP-TR 130 | MP-TR 130 | MP-TR 130 | MP-TR 160 | 0.34 |
| | 9.6 | MP-TR 080 | MP-TR 080 | MP-TR 080 | MP-TR 105 | MP-TR 105 | MP-TR 105 | MP-TR 105 | MP-TR 105 | MP-TR 130 | MP-TR 130 | MP-TR 130 | MP-TR 160 | 0.47 |
| BMD 118 | 5.6 | MP-TR 105 | MP-TR 105 | MP-TR 105 | MP-TR 105 | MP-TR 105 | MP-TR 105 | MP-TR 105 | MP-TR 105 | MP-TR 105 | MP-TR 130 | MP-TR 130 | MP-TR 160 | 0.45 |
| | 10.2 | MP-TR 105 | MP-TR 105 | MP-TR 105 | MP-TR 105 | MP-TR 105 | MP-TR 130 | MP-TR 130 | MP-TR 130 | MP-TR 130 | MP-TR 130 | MP-TR 160 | MP-TR 190 | 0.78 |
| | 14.0 | MP-TR 105 | MP-TR 105 | MP-TR 105 | MP-TR 105 | MP-TR 105 | MP-TR 130 | MP-TR 130 | MP-TR 130 | MP-TR 130 | MP-TR 130 | MP-TR 160 | MP-TR 190 | 0.99 |
| BMD 145 | 16.8 | MP-TR 105 | MP-TR 105 | MP-TR 105 | MP-TR 105 MP-TR 130 | MP-TR 105 MP-TR 130 | MP-TR 130 | MP-TR 130 | MP-TR 130 | MP-TR 160 | MP-TR 160 | MP-TR 190 | | 1.28 |
| | 22.0 | MP-TR 105 | MP-TR 105 | MP-TR 105 | MP-TR 105 MP-TR 130 | MP-TR 130 | MP-TR 160 | MP-TR 130 | MP-TR 130 | MP-TR 160 | MP-TR 160 | MP-TR 190 | | 1.76 |
| BMD 170 | 34.0 | MP-TR 105 | MP-TR 105 MP-TR 130 | MP-TR 130 | MP-TR 130 | MP-TR 130 | MP-TR 160 | MP-TR 160 | MP-TR 160 | MP-TR 190 | | | | 3.38 |
| | 45.0 | MP-TR 130 | MP-TR 130 | MP-TR 130 | MP-TR 130 MP-TR 160 | MP-TR 130 MP-TR 160 | MP-TR 190 | MP-TR 160 | MP-TR 160 | MP-TR 190 | | | | 4.75 |

| DISTRIBUTION OF GEARBOX OUTPUT TORQUE [Nm] | | | | | | | | | | | | |
|--|-----|-----|-----|-----|-----|-----|------|------|------|------|------|------|
| | 3 | 4 | 5 | 6 | 7 | 10 | 16 | 20 | 25 | 40 | 50 | 70 |
| MP-TR 053 | 12 | 15 | 15 | 15 | 15 | - | 20 | 20 | 20 | - | - | - |
| MP-TR 060 | 18 | 25 | 25 | 25 | 25 | 18 | 30 | 30 | 30 | 30 | 30 | 30 |
| MP-TR 080 | 40 | 50 | 50 | 50 | 50 | 40 | 70 | 70 | 70 | 70 | 70 | 70 |
| MP-TR 105 | 100 | 140 | 140 | 140 | 140 | 100 | 170 | 170 | 170 | 170 | 170 | 170 |
| MP-TR 130 | 215 | 380 | 380 | 380 | 380 | 215 | 450 | 450 | 450 | 450 | 450 | 450 |
| MP-TR 160 | 350 | 500 | 500 | 500 | 500 | 350 | 700 | 700 | 700 | 700 | 700 | 700 |
| MP-TR 190 | 500 | 700 | 700 | 700 | 700 | 500 | 1000 | 1000 | 1000 | 1000 | 1000 | 1000 |

Notes:

Input speed lower than 3000 min⁻¹.

Safety factor 1 < S ≤ 4.

For any additional technical information about gearboxes selection see relevant catalogues.

BMD Servomotor / TQ series Precision Planetary Gearbox combination

RATIOS FROM 3:1 TO 70:1

| TYPE | MOTOR STALL TORQUE | RATIOS | | | | | | | | | | | MOTOR INERTIA |
|---------|--------------------|------------------|------------------|------------------|------------------|------------------|------------------|------------------|------------------|------------------|------------------|------------------|-------------------------------------|
| | [Nm] | 3:1 | 4:1 | 5:1 | 7:1 | 10:1 | 16:1 | 20:1 | 25:1 | 40:1 | 50:1 | 70:1 | kgm ² x 10 ⁻³ |
| BMD 65 | 0,85 | | | | | TQ 060 | TQ 060 | TQ 060 | TQ 060 TQ 070 | TQ 070 | TQ 070 | TQ 070 | 0,02 |
| | 1,7 | TQ 060 TQ 070 | TQ 060 TQ 070 | TQ 060 TQ 070 | TQ 060 TQ 070 | TQ 060 TQ 070 | TQ 060 TQ 070 | TQ 070 | TQ 070 | TQ 070 | | | 0,04 |
| | 2,2 | TQ 060 TQ 070 | TQ 060 TQ 070 | TQ 060 TQ 070 | TQ 060 TQ 070 | TQ 070 | TQ 070 | TQ 070 | TQ 070 | | | | 0,06 |
| BMD 82 | 3,2 | TQ 070 | TQ 070 | TQ 070 | TQ 070 | TQ 090 | TQ 070 | TQ 070 | TQ 090 | TQ 090 | TQ 090 | | 0,14 |
| | 4,4 | TQ 070 | TQ 070 | TQ 070 | TQ 070 | TQ 090 | TQ 090 | TQ 090 | TQ 090 | TQ 090 | | | 0,17 |
| BMD 102 | 4,0 | TQ 070 | TQ 070 | TQ 070 | TQ 070 | TQ 070 TQ 090 | TQ 070 TQ 090 | TQ 070 TQ 090 | TQ 090 | TQ 090 | TQ 090 | TQ 130 | 0,19 |
| | 7,2 | TQ 070 | TQ 070 | TQ 070 TQ 090 | TQ 070 TQ 090 | TQ 090 | TQ 090 | TQ 090 | TQ 090 | TQ 130 | TQ 130 | | 0,34 |
| | 9,6 | TQ 070 | TQ 090 | TQ 090 TQ 090 | TQ 070 TQ 090 | TQ 090 | TQ 090 | TQ 130 | TQ 130 | TQ 130 | | | 0,47 |
| BMD 118 | 5,6 | TQ 070 | TQ 070 | TQ 070 | TQ 070 | TQ 090 | TQ 090 | TQ 090 TQ 130 | TQ 090 TQ 130 | TQ 130 TQ 160 | TQ 130 TQ 160 | TQ 130 TQ 160 | 0,45 |
| | 10,2 | TQ 070 TQ 090 | TQ 070 TQ 090 | TQ 070 TQ 090 | TQ 090 | TQ 090 | TQ 130 | TQ 130 | TQ 130 TQ 160 | TQ 130 TQ 160 | TQ 160 | TQ 160 | 0,78 |
| | 14,0 | TQ 070 TQ 090 | TQ 070 TQ 090 | TQ 090 | TQ 090 TQ 130 | TQ 130 | TQ 130 | TQ 130 TQ 160 | TQ 130 TQ 160 | TQ 160 | TQ 160 | | 0,99 |
| BMD 145 | 16,8 | TQ 090 | TQ 090 | TQ 090 | TQ 090 TQ 130 | TQ 130 | TQ 160 | TQ 160 | TQ 160 | TQ 160 | | | 1,28 |
| | 22,0 | TQ 090 | TQ 090 | TQ 090 | TQ 090 TQ 130 | TQ 130 | TQ 160 | TQ 160 | TQ 160 | | | | 1,76 |
| BMD 170 | 34,0 | TQ 090 TQ 130 | TQ 090 TQ 130 | TQ 090 TQ 130 | TQ 130 | TQ 160 | TQ 160 | TQ 160 | | | | | 3,38 |
| | 45,0 | TQ 130 | TQ 130 | TQ 130 | TQ 130 | TQ 160 | TQ 160 | | | | | | 4,75 |

| DISTRIBUTION OF GEARBOX OUTPUT TORQUE [Nm] | | | | | | | | | | | |
|--|-----|-----|-----|-----|-----|-----|-----|-----|-----|-----|-----|
| | 3 | 4 | 5 | 7 | 10 | 16 | 20 | 25 | 40 | 50 | 70 |
| TQ 060 | 21 | 30 | 30 | 25 | 20 | 30 | 30 | 30 | 30 | 30 | 25 |
| TQ 070 | 45 | 70 | 70 | 60 | 40 | 70 | 70 | 70 | 70 | 70 | 60 |
| TQ 090 | 130 | 200 | 180 | 160 | 110 | 200 | 180 | 180 | 200 | 180 | 160 |
| TQ 130 | 260 | 400 | 400 | 360 | 280 | 400 | 400 | 400 | 400 | 400 | 360 |
| TQ 160 | 530 | 800 | 800 | 750 | 550 | 800 | 800 | 800 | 800 | 800 | 750 |

Notes:

Input speed lower than 3000 min⁻¹.

Safety factor 1 < S ≤ 4.

For any additional technical information about gearboxes selection see relevant catalogues.

BMD Servomotor / TQF series Precision Planetary Flanged Gearbox combination

RATIOS FROM 4:1 TO 70:1

| TYPE | MOTOR STALL TORQUE | | | | | | | | | | | MOTOR INERTIA |
|---------|--------------------|--------------------|--------------------|--------------------|--------------------|--------------------|--------------------|--------------------|--------------------|--------------------|--------------------|---------------|
| | [Nm] | 4:1 | 5:1 | 7:1 | 10:1 | 16:1 | 20:1 | 25:1 | 40:1 | 50:1 | 70:1 | |
| BMD 65 | 0,85 | | | | TQF 060 | TQF 060 | TQF 060 | TQF 060 TQF 070 | TQF 070 | TQF 070 | TQF 070 | 0,02 |
| | 1,7 | TQF 060 TQF 070 | TQF 060 TQF 070 | TQF 060 TQF 070 | TQF 060 TQF 070 | TQF 060 TQF 070 | TQF 070 | TQF 070 | TQF 070 | | | 0,04 |
| | 2,2 | TQF 060 TQF 070 | TQF 060 TQF 070 | TQF 060 TQF 070 | TQF 070 | TQF 070 | TQF 070 | TQF 070 | | | | 0,06 |
| BMD 82 | 3,2 | TQF 070 | TQF 070 | TQF 070 | TQF 090 | TQF 070 | TQF 070 | TQF 090 | TQF 090 | TQF 090 | | 0,14 |
| | 4,4 | TQF 070 | TQF 070 | TQF 070 | TQF 090 | TQF 090 | TQF 090 | TQF 090 | TQF 090 | | | 0,17 |
| BMD 102 | 4,0 | TQF 070 | TQF 070 | TQF 070 | TQF 070 TQF 090 | TQF 070 TQF 090 | TQF 070 TQF 090 | TQF 090 | TQF 090 | TQF 090 | TQF 130 | 0,19 |
| | 7,2 | TQF 070 | TQF 070 TQF 090 | TQF 070 TQF 090 | TQF 090 | TQF 090 | TQF 090 | TQF 090 | TQF 130 | TQF 130 | | 0,34 |
| | 9,6 | TQF 090 | TQF 090 TQF 090 | TQF 070 TQF 090 | TQF 090 | TQF 090 | TQF 130 | TQF 130 | TQF 130 | | | 0,47 |
| BMD 118 | 5,6 | TQF 070 | TQF 070 | TQF 070 | TQF 090 | TQF 090 | TQF 090 TQF 130 | TQF 090 TQF 130 | TQF 130 TQF 160 | TQF 130 TQF 160 | TQF 130 TQF 160 | 0,45 |
| | 10,2 | TQF 070 TQF 090 | TQF 070 TQF 090 | TQF 090 | TQF 090 | TQF 130 | TQF 130 | TQF 130 TQF 160 | TQF 130 TQF 160 | TQF 160 | TQF 160 | 0,78 |
| | 14,0 | TQF 070 TQF 090 | TQF 090 | TQF 090 TQF 130 | TQF 130 | TQF 130 | TQF 130 TQF 160 | TQF 130 TQF 160 | TQF 160 | TQF 160 | | 0,99 |
| BMD 145 | 16,8 | TQF 090 | TQF 090 | TQF 090 TQF 130 | TQF 130 | TQF 160 | TQF 160 | TQF 160 | TQF 160 | | | 1,28 |
| | 22,0 | TQF 090 | TQF 090 | TQF 090 TQF 130 | TQF 130 | TQF 160 | TQF 160 | TQF 160 | | | | 1,76 |
| BMD 170 | 34,0 | TQF 090 TQF 130 | TQF 090 TQF 130 | TQF 130 | TQF 160 | TQF 160 | TQF 160 | | | | | 3,38 |
| | 45,0 | TQF 130 | TQF 130 | TQF 130 | TQF 160 | TQF 160 | | | | | | 4,75 |

| DISTRIBUTION OF GEARBOX OUTPUT TORQUE [Nm] | | | | | | | | | | |
|--|-----|-----|-----|-----|-----|-----|-----|-----|-----|-----|
| | 4 | 5 | 7 | 10 | 16 | 20 | 25 | 40 | 50 | 70 |
| TQF 060 | 30 | 30 | 25 | 20 | 30 | 30 | 30 | 30 | 30 | 25 |
| TQF 070 | 70 | 70 | 60 | 40 | 70 | 70 | 70 | 70 | 70 | 60 |
| TQF 090 | 200 | 180 | 160 | 110 | 200 | 180 | 180 | 200 | 180 | 160 |
| TQF 130 | 400 | 400 | 360 | 280 | 400 | 400 | 400 | 400 | 400 | 360 |
| TQF 160 | 800 | 800 | 750 | 550 | 800 | 800 | 800 | 800 | 800 | 750 |

Notes:

Input speed lower than 3000 min⁻¹.

Safety factor 1 < S ≤ 4.

For any additional technical information about gearboxes selection see relevant catalogues.

Global Presence



Bonfiglioli is a market force with a presence spanning 22 countries on 5 continents. Our organization makes the most of geographic proximity to offer complete solutions combining efficiency and competence.



3780
EMPLOYEES



20
BRANCHES



13
PLANTS



550
DISTRIBUTORS



80
COUNTRIES

We Are a Global Company

Thanks to an international network of sales branches and closely interconnecting production plants, we can guarantee the same high standards of Bonfiglioli quality anywhere at any given time. Aware that our direct presence in local markets is the key to long-lasting success, our family includes 20 sales branches, 13 production plants and more than 500 distributors around the world.

Our organization is always close by, offering complete and efficient solutions and supporting our customers with dedicated services, such as co-engineering or after-sales assistance.



Bonfiglioli Worldwide Locations

Australia

Bonfiglioli Transmission (Aust.) Pty Ltd.

2, Cox Place Glendenning NSW 2761
Locked Bag 1000 Plumpton NSW 2761
Tel. +61 2 8811 8000

Brazil

Bonfiglioli Redutores do Brasil Ltda.

Travessa Cláudio Armando 171 - Bloco 3 - CEP 09861-730
Bairro Assunção - São Bernardo do Campo - São Paulo
Tel. +55 11 4344 2322

China

Bonfiglioli Drives (Shanghai) Co. Ltd.

#68, Hui-Lian Road, QingPu District,
201707 Shanghai
Tel. +86 21 6700 2000

France

Bonfiglioli Transmission s.a.

14 Rue Eugène Pottier
Zone Industrielle de Moimont II - 95670 Marly la Ville
Tel. +33 1 34474510

Germany

Bonfiglioli Deutschland GmbH

Sperberweg 12 - 41468 Neuss
Tel. +49 0 2131 2988 0

Bonfiglioli Vectron GmbH

Europark Fichtenhain B6 - 47807 Krefeld
Tel. +49 0 2151 8396 0

O&K Antriebstechnik GmbH

Ruhrallee 8-12 - 45525 Hattingen
Tel. +49 0 2324 2050 1

India

Bonfiglioli Transmissions Pvt. Ltd.

Mobile, Wind

AC 7 - AC 11 Sidco Industrial Estate
Thirumudivakkam Chennai - 600 044
Tel. +91 844 844 8649

Industrial

Survey No. 528/1, Perambakkam High Road Mannur Village,
Sriperumbudur Taluk Chennai - 602 105
Tel. +91 844 844 8649

Industrial

Plot No.A-9/5, Phase IV MIDC Chakan,
Village Nighoje Pune - 410 501
Tel. +91 844 844 8649

Italy

Bonfiglioli Riduttori S.p.A.

Headquarters

Via Giovanni XXIII, 7/A - 40012 Lippo di Calderara di Reno
Tel. +39 051 647 3111

EVO - Industrial

Via Bazzane, 33/A - 40012 Calderara di Reno
Tel. +39 051 6473111

Mobile, Wind

Via Enrico Mattei, 12 Z.I. Villa Selva - 47100 Forlì
Tel. +39 0543 789111

Bonfiglioli Italia S.p.A

Via Sandro Pertini lotto 7b - 20080 Carpiano
Tel. +39 02 985081

Bonfiglioli Mechatronic Research S.p.A

Via Unione 49 - 38068 Rovereto
Tel. +39 0464 443435/36

New Zealand

Bonfiglioli Transmission (Aust.) Pty Ltd.

88 Hastie Avenue, Mangere Bridge, 2022 Auckland
PO Box 11795, Ellerslie
Tel. +64 09 634 6441

Singapore

Bonfiglioli South East Asia Pte Ltd.

8 Boon Lay Way, #04-09,
8@ Tadehub 21, Singapore 609964
Tel. +65 6268 9869

Slovakia

Bonfiglioli Slovakia s.r.o.

Robotnícka 2129
Považská Bystrica, 01701 Slovakia
Tel. +421 42 430 75 64

South Africa

Bonfiglioli South Africa Pty Ltd.

55 Galaxy Avenue, Linbro Business Park, Sandton,
Johannesburg, 2090 South Africa
Tel. +27 11 608 2030

Spain

Tecnotrans Bonfiglioli, S.A.

Pol. Ind. Zona Franca, Sector C, Calle F, nº 6
08040 Barcelona
Tel. +34 93 447 84 00

Turkey

Bonfiglioli Turkey Jsc

Atatürk Organize Sanayi Bölgesi, 10007 Sk. No. 30
Atatürk Organize Sanayi Bölgesi, 35620 Çiğli - Izmir
Tel. +90 0 232 328 22 77

United Kingdom

Bonfiglioli UK Ltd.

Unit 1 Calver Quay, Calver Road, Winwick
Warrington, Cheshire - WA2 8UD
Tel. +44 1925 852667

USA

Bonfiglioli USA Inc.

3541 Hargrave Drive
Hebron, Kentucky 41048
Tel. +1 859 334 3333

Vietnam

Bonfiglioli Vietnam Ltd.

Lot C-9D-CN My Phuoc Industrial Park 3
Ben Cat - Binh Duong Province
Tel. +84 650 3577411



We have a relentless commitment to excellence, innovation and sustainability. Our team creates, distributes and services world-class power transmission and drive solutions to keep the world in motion.

HEADQUARTERS

Bonfiglioli Riduttori S.p.A.
Via Giovanni XXIII, 7/A
40012 Lippo di Calderara di Reno
Bologna (Italy)
www.bonfiglioli.com

